

1-1

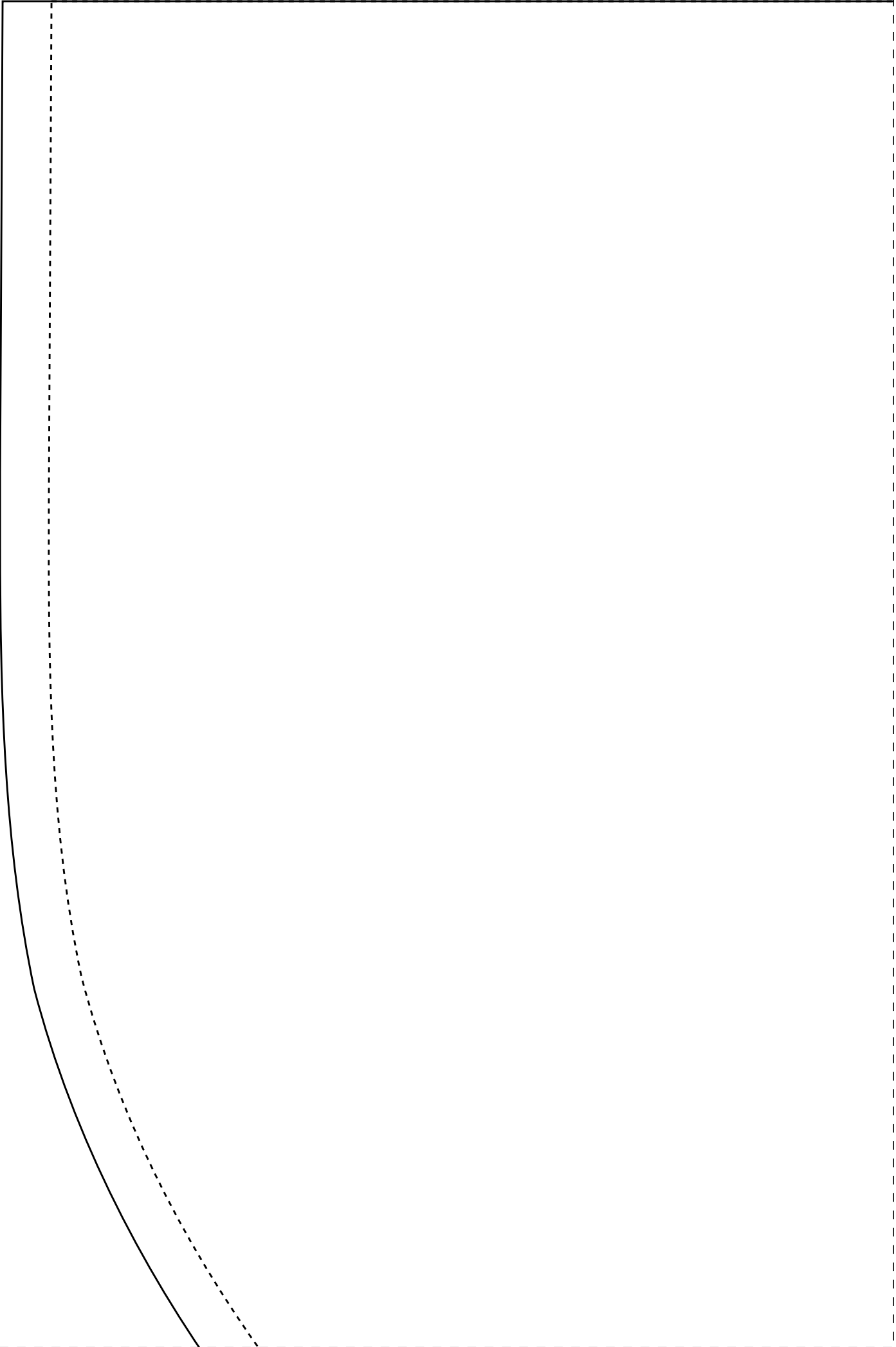

2-1

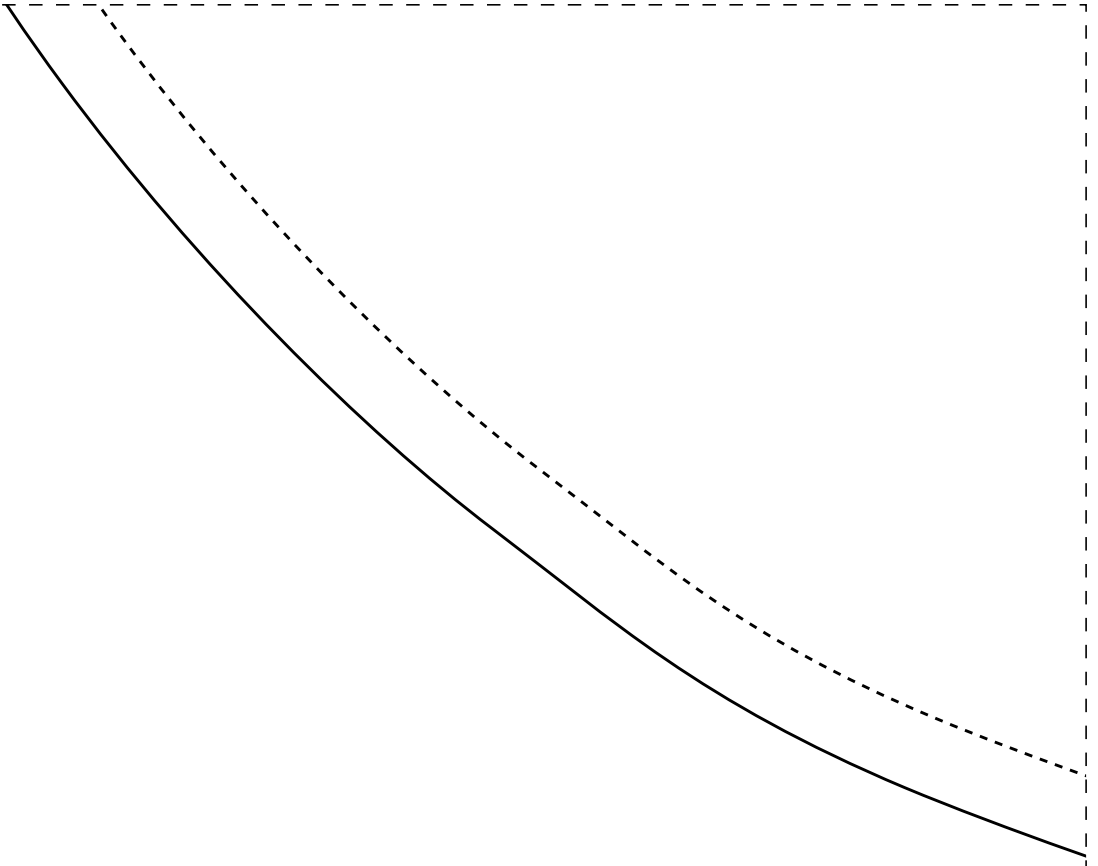

MARTINGALE 2X-44

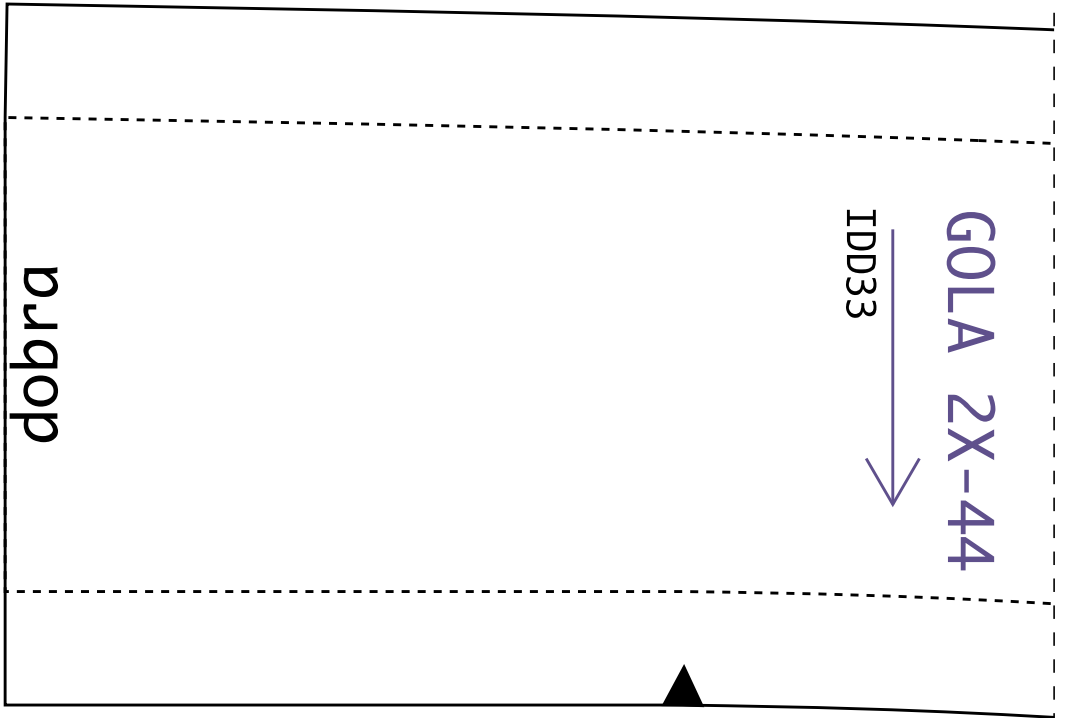
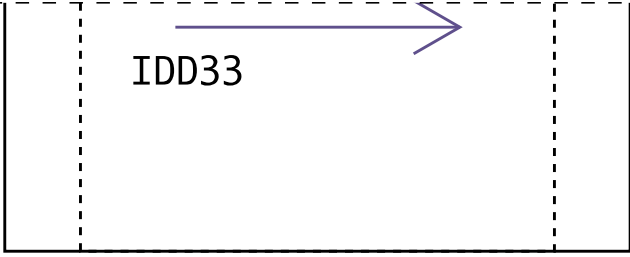



IDD33

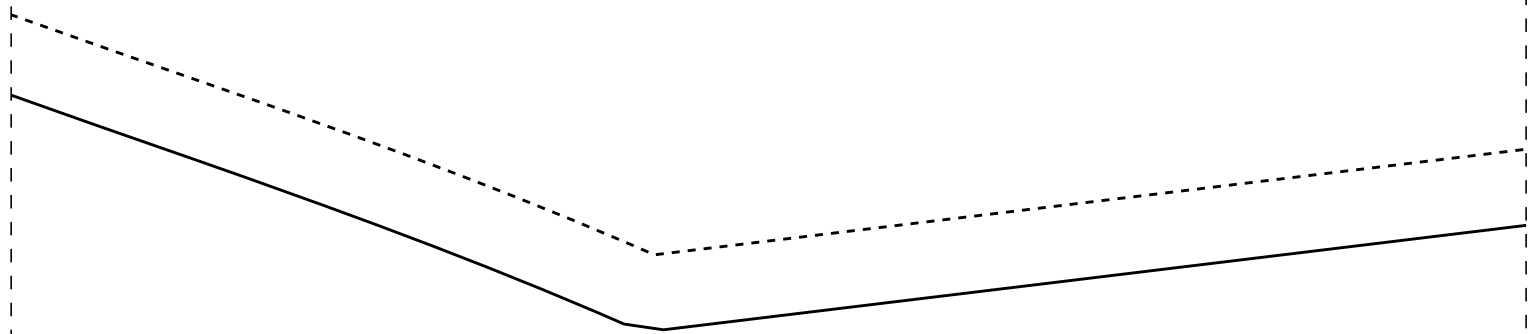

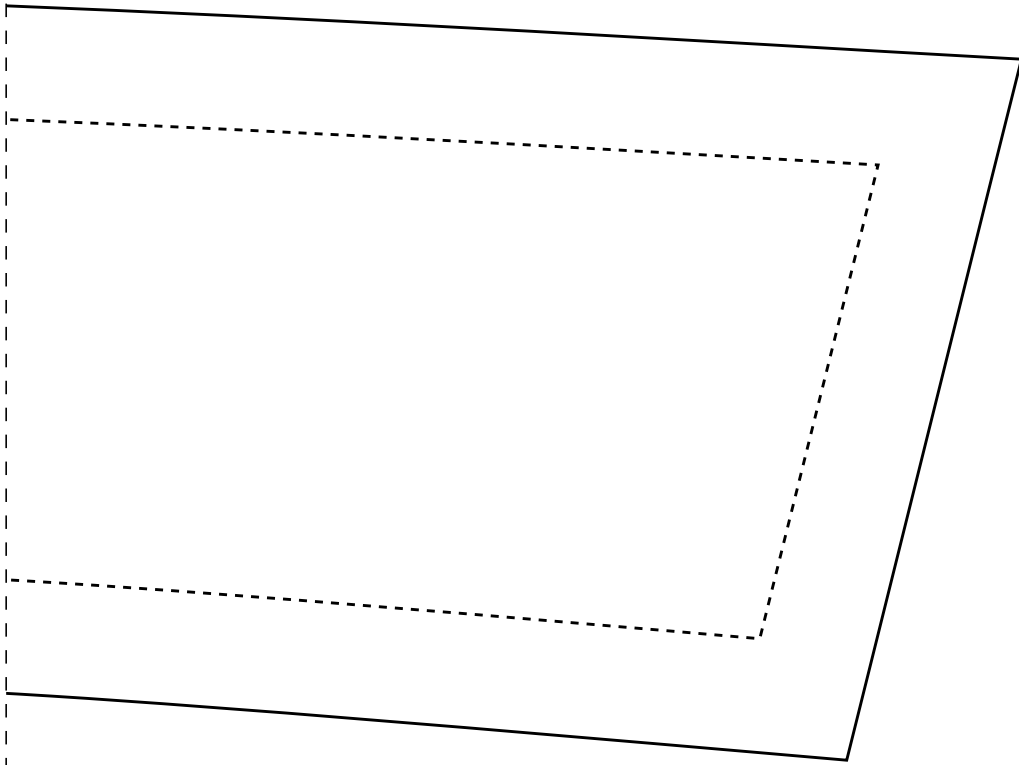

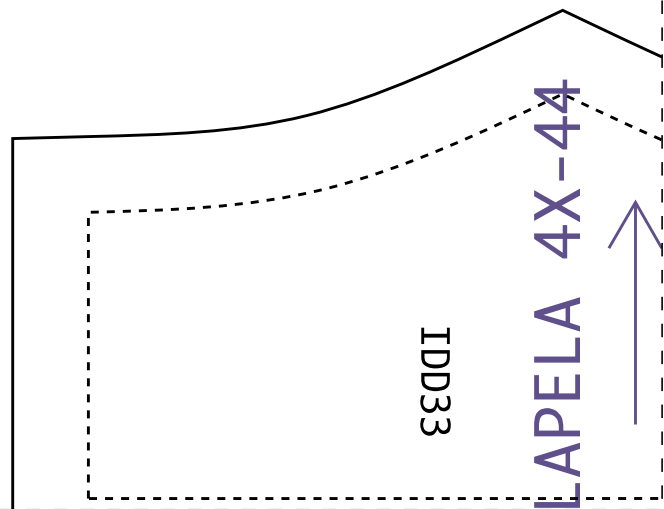
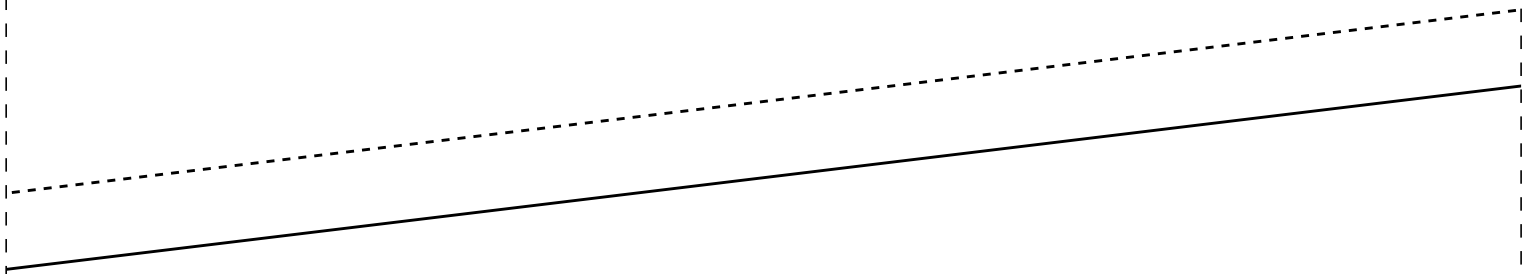

IDD33

LAPELA 4X-44



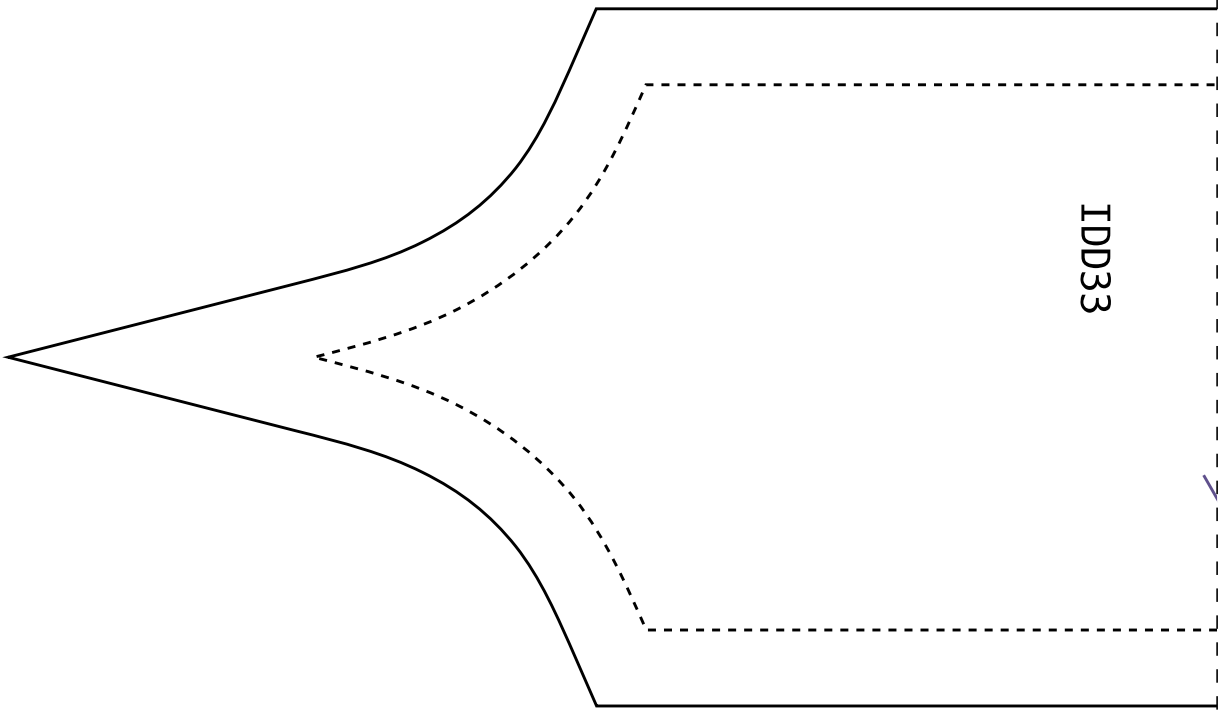

IDD33

2-4

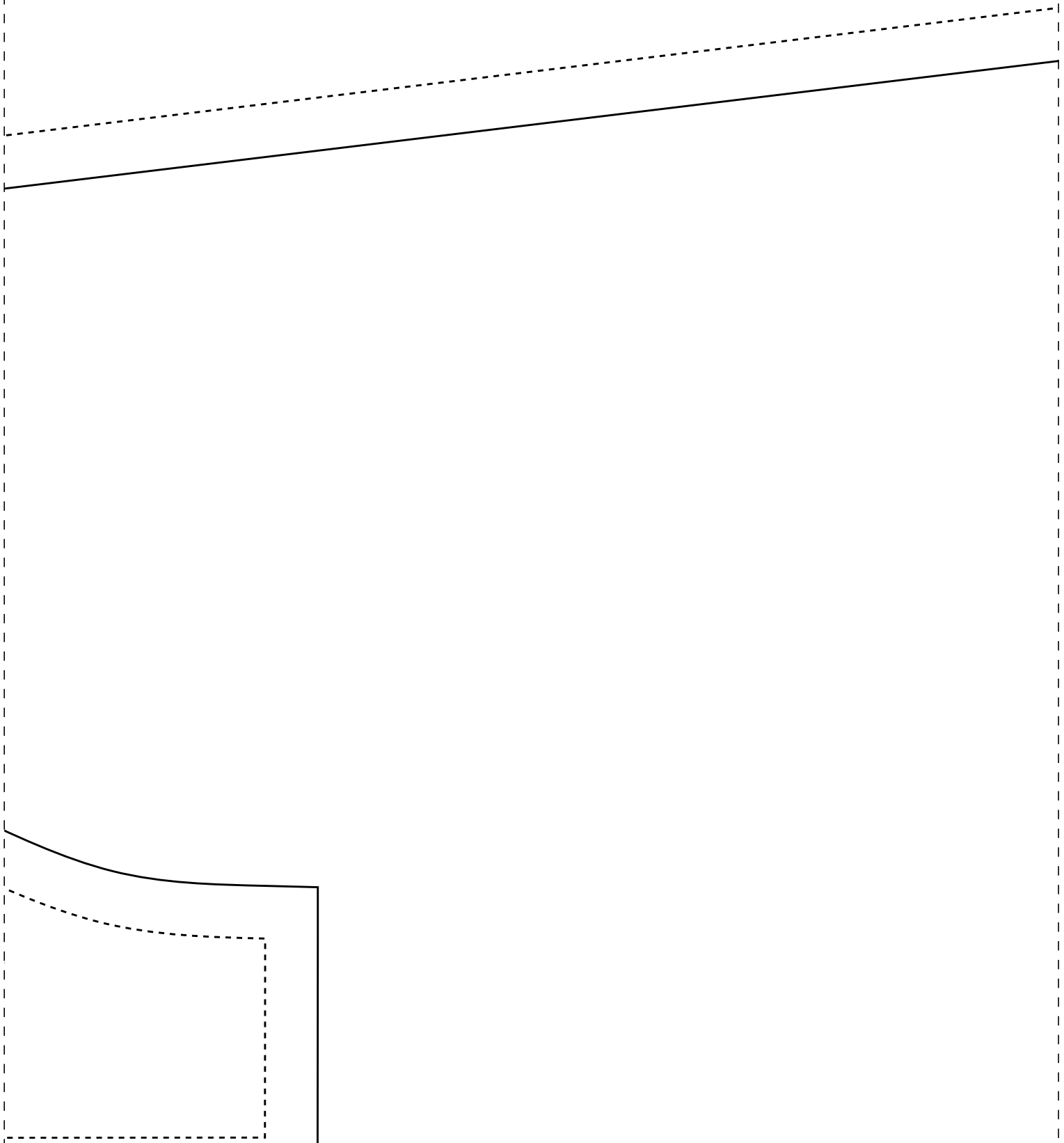

dobra

punho 2x-44





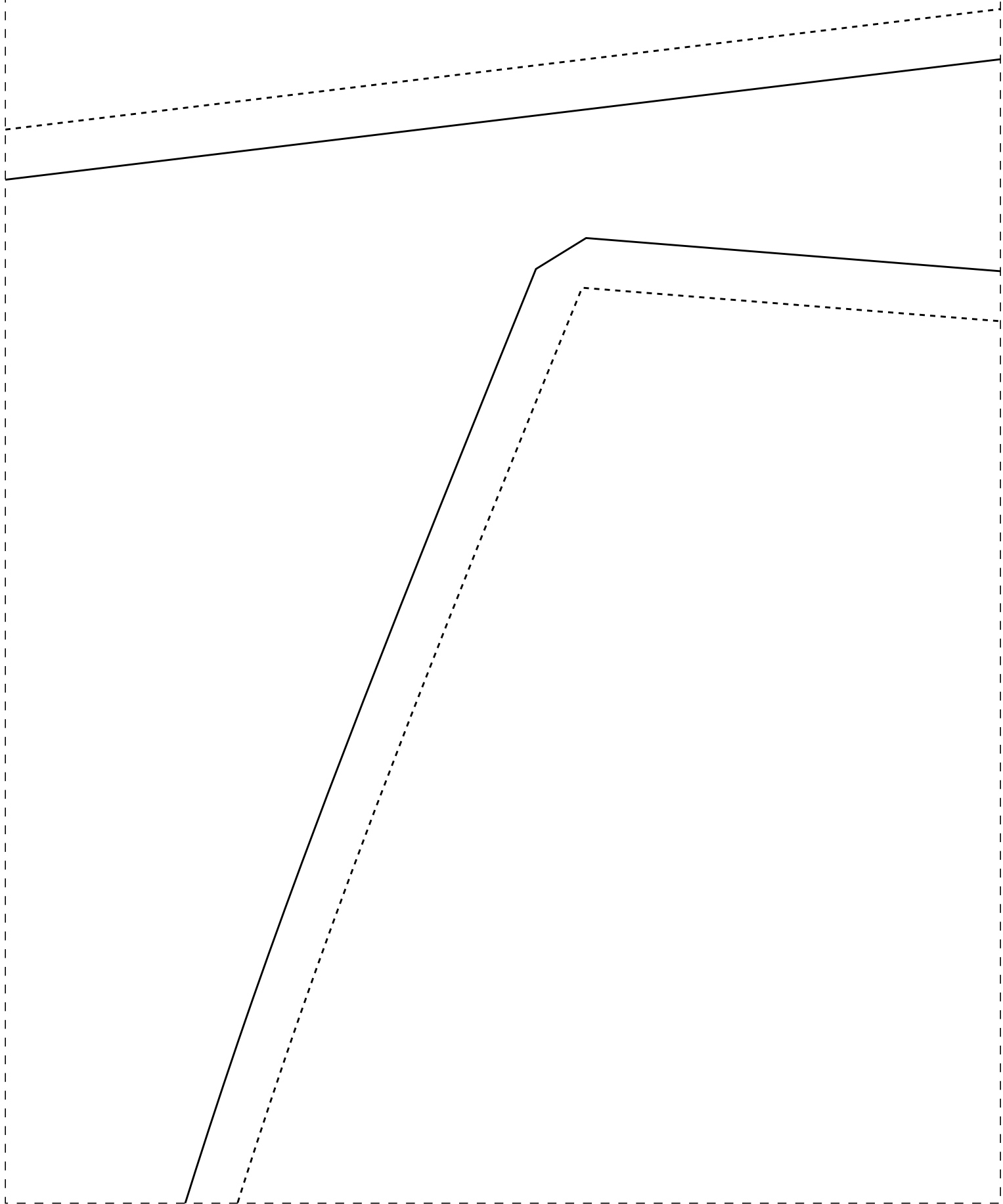

3-5

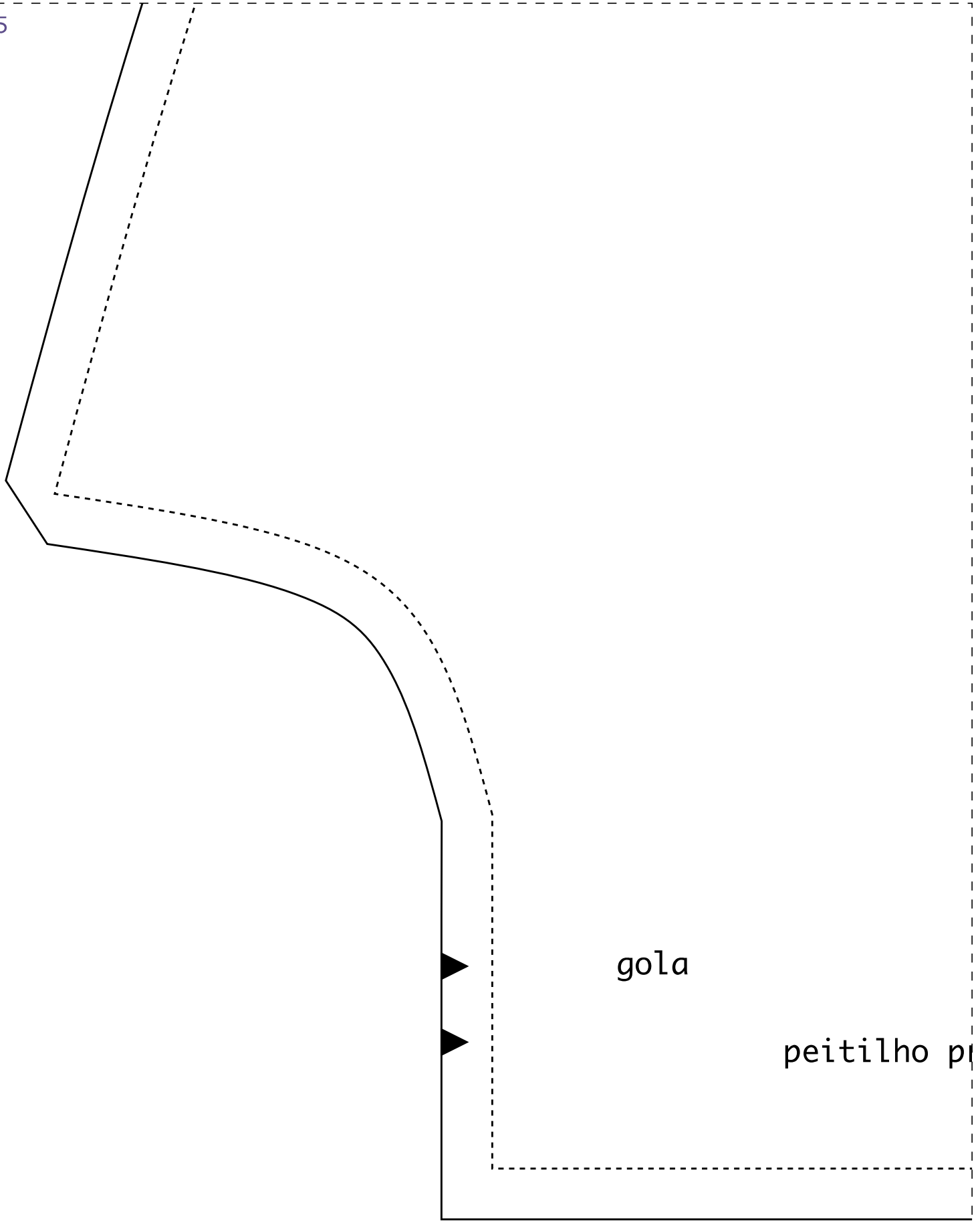

gola

peitilho p



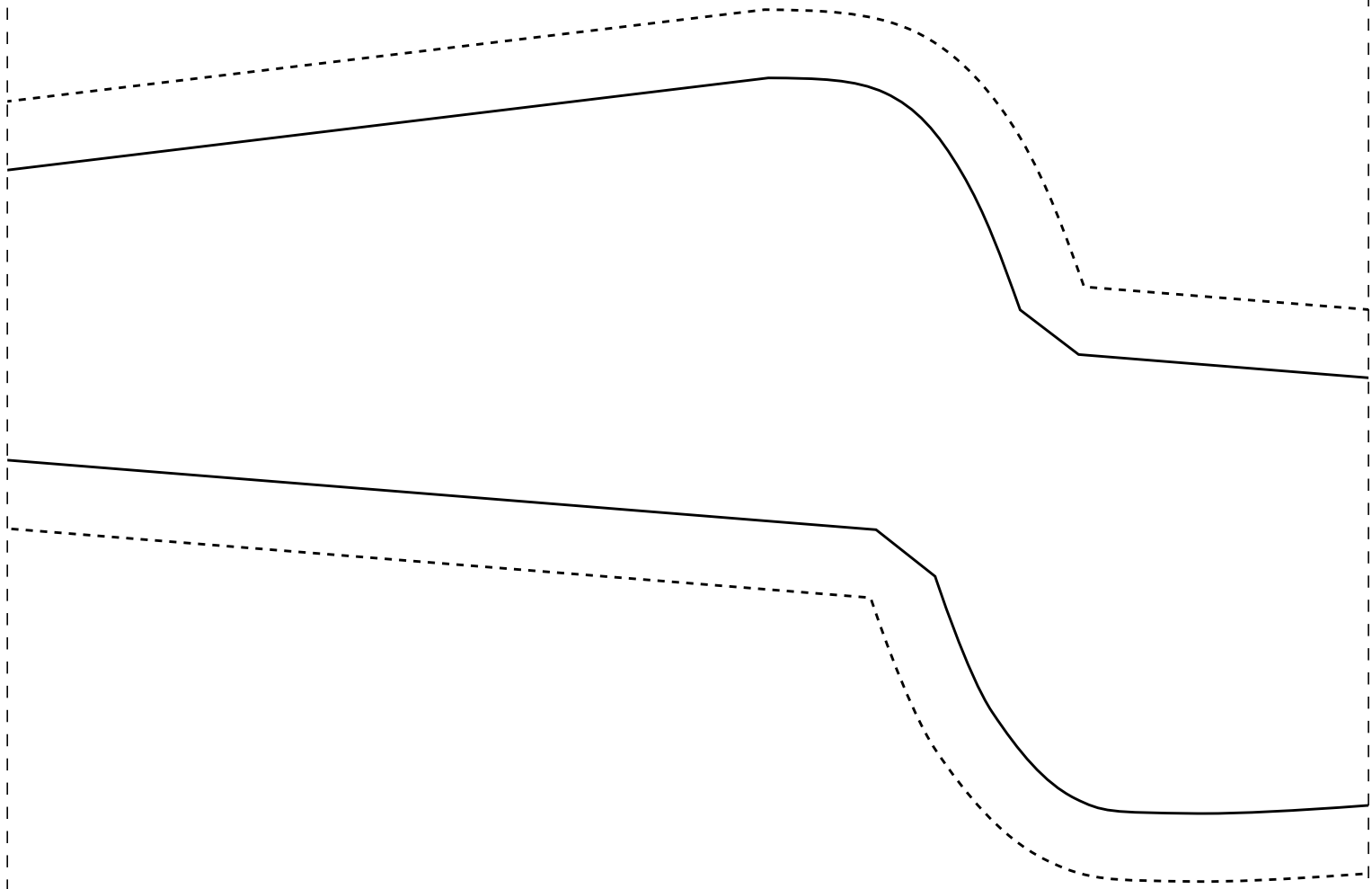

3-6

Lapela/bolso

fronto 2,5cm

2-7

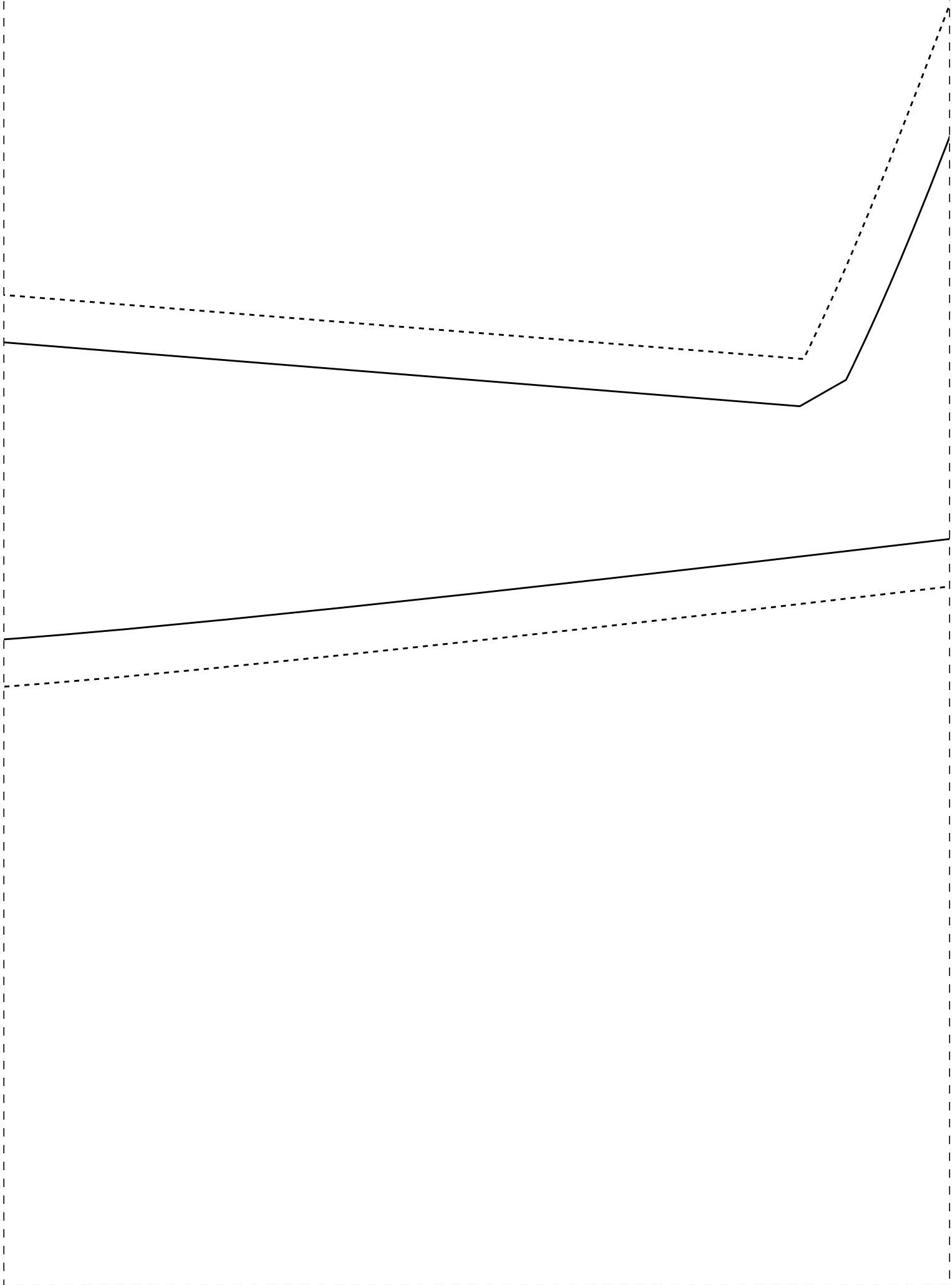

IDD33

1-8

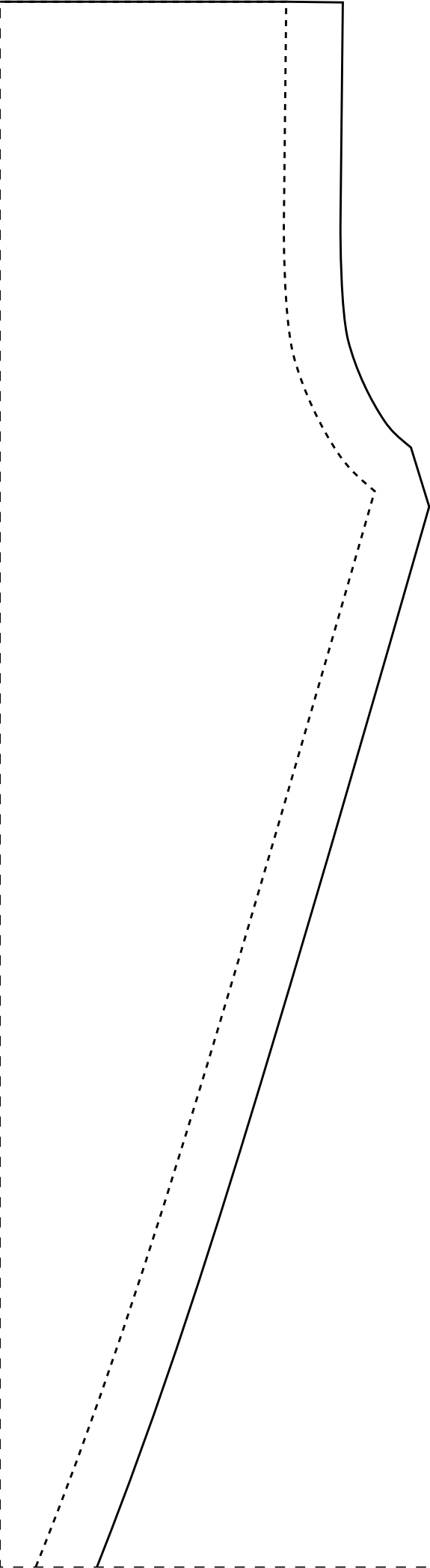

2-8

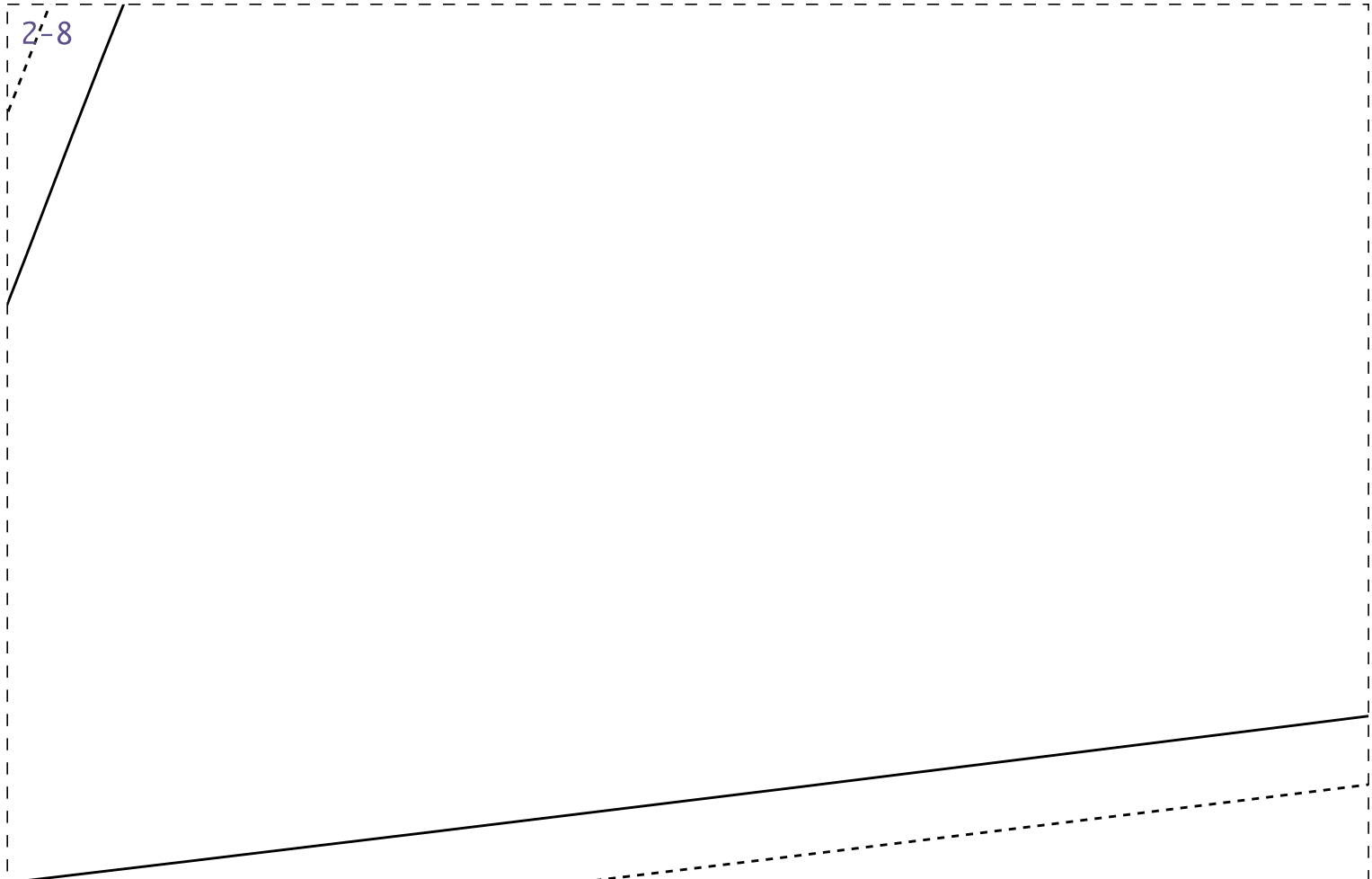

FICHA TÉCNICA:

- Tecido plano 1,4m de largura
- Viscolinho, linho, viscose ou similares
- Peça com martingale, bolso e lapela
- Manga com punho
- Peitilho dobrado na peça pronto com 2,5cm
- Fechamento com caseado e botões
- Bainha de lenço ou viés
- 3,3m para todos os tamanhos

dobra

--

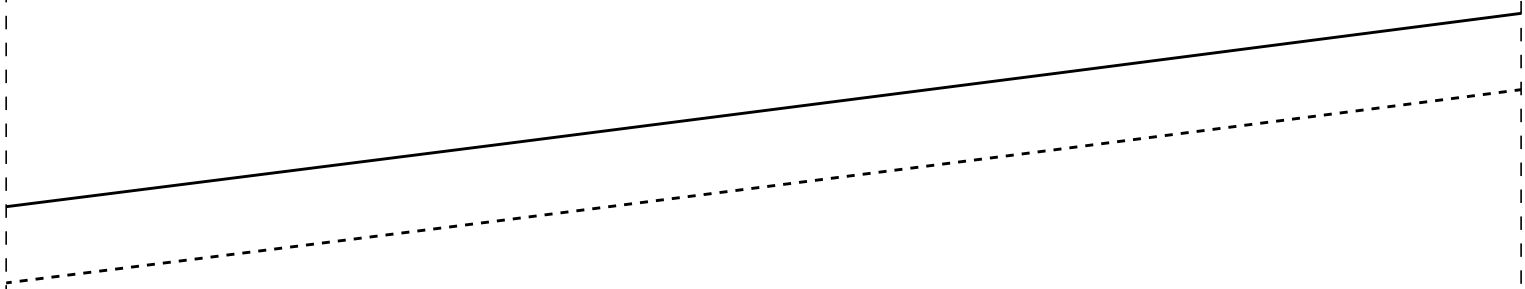

Teste de impressão: ao imprimir seu molde, meça o quadrado que deverá ter a mesma medida informada (4cm), assim você se certificará que ele foi impresso no tamanho correto.

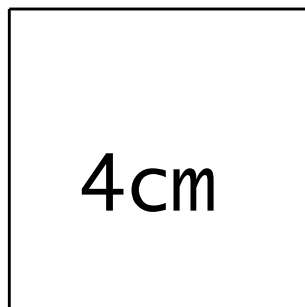

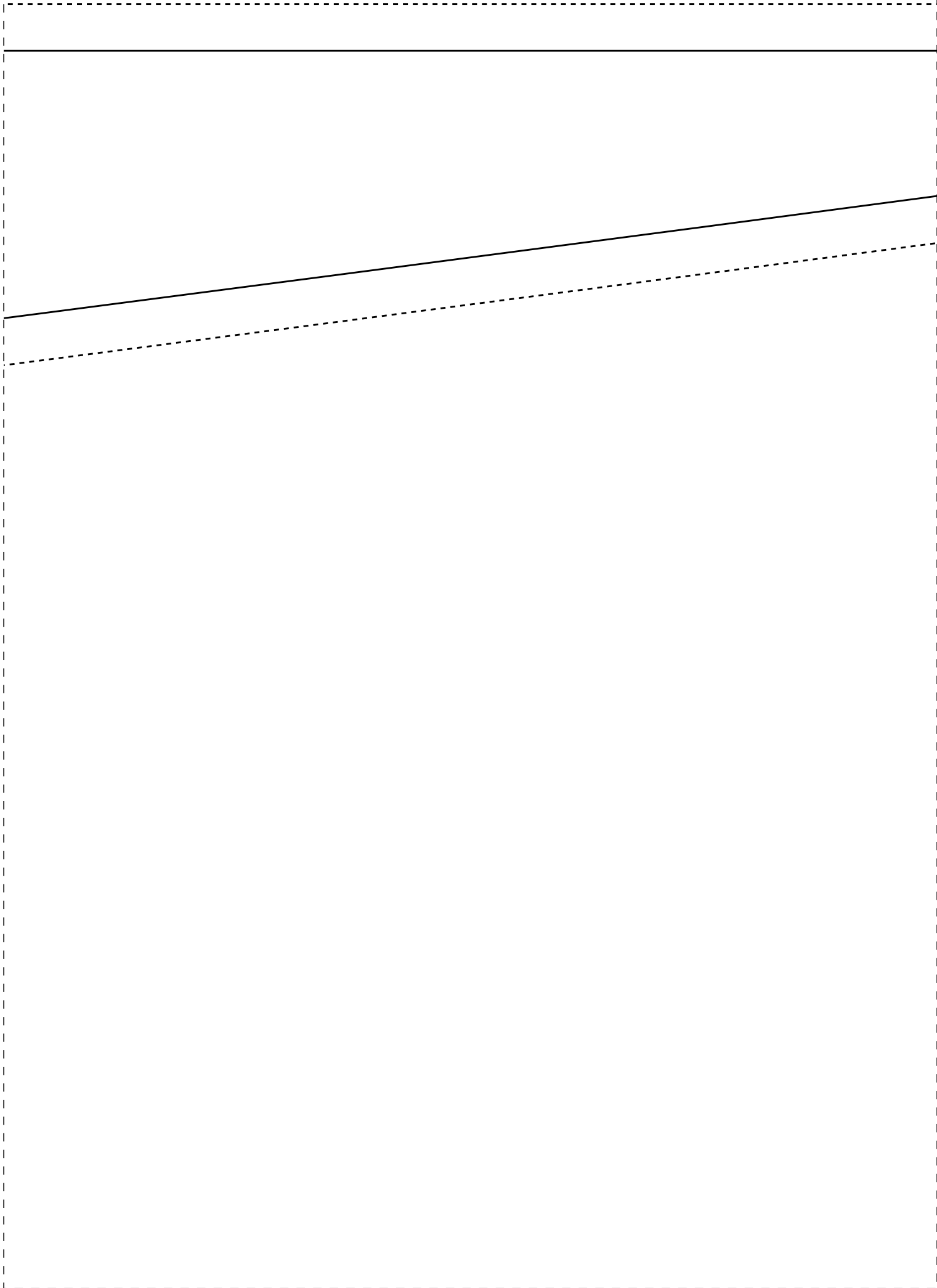

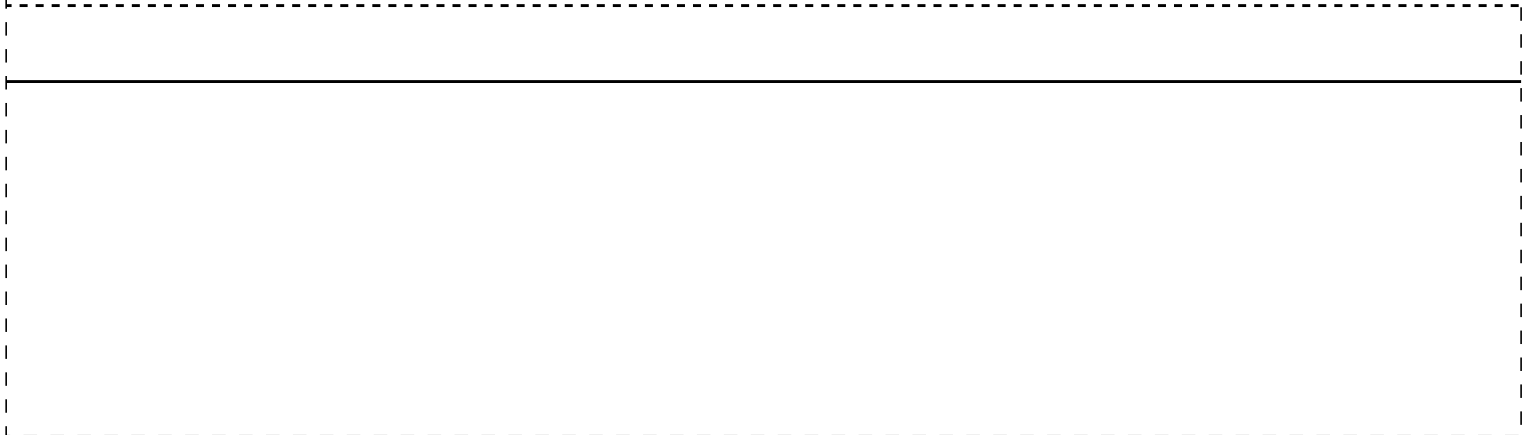

1-11

IDD33



CINTO 1X-42

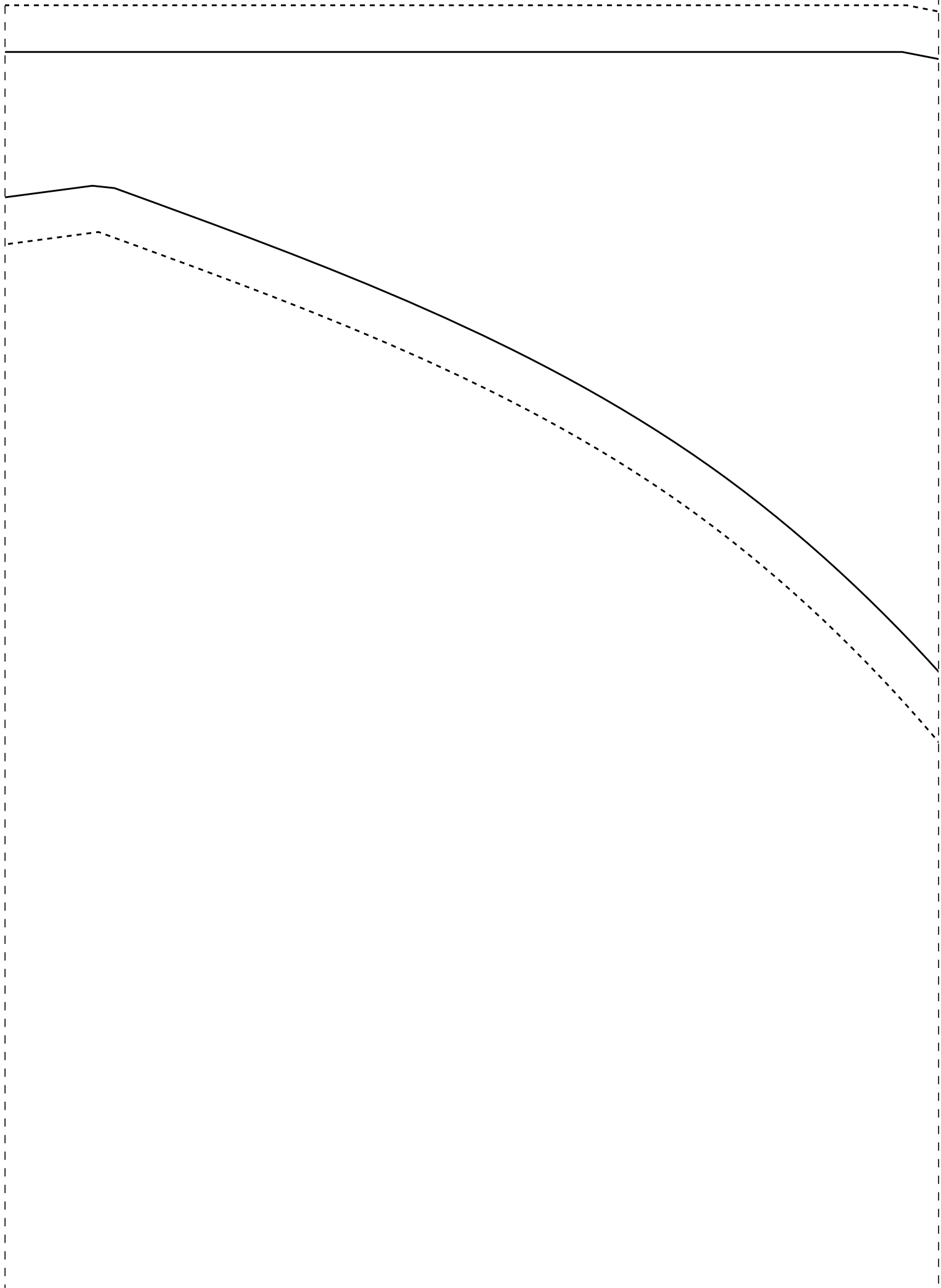

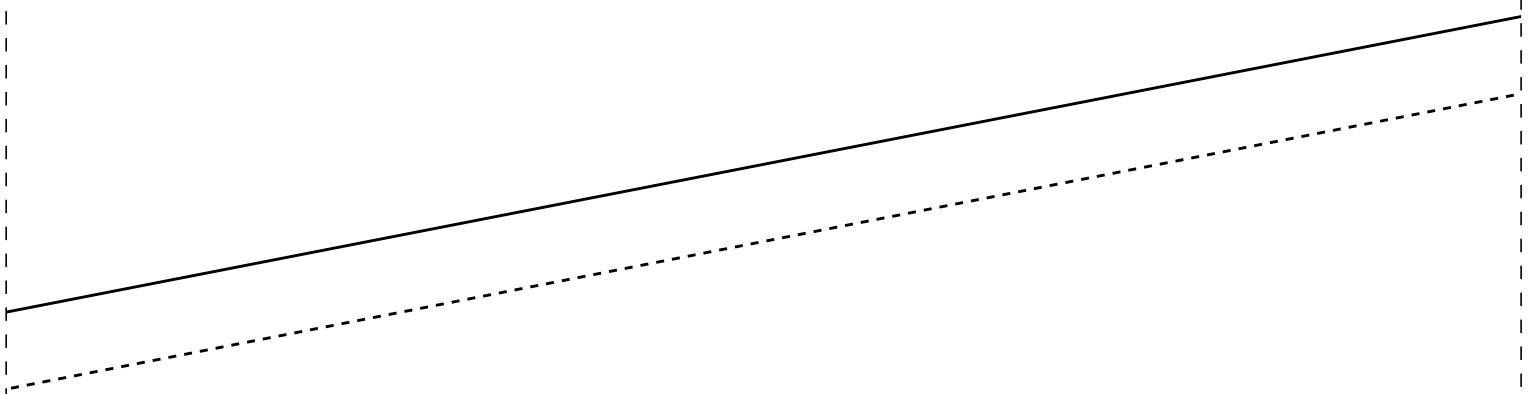

2-12

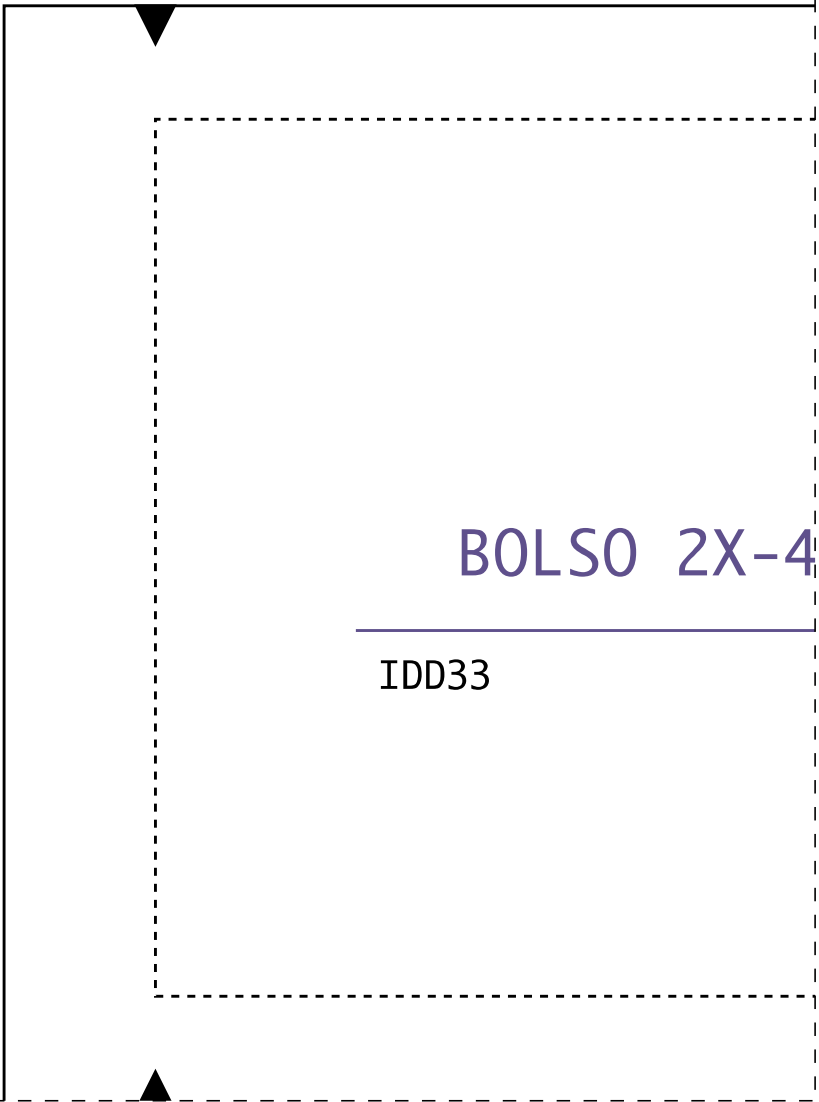
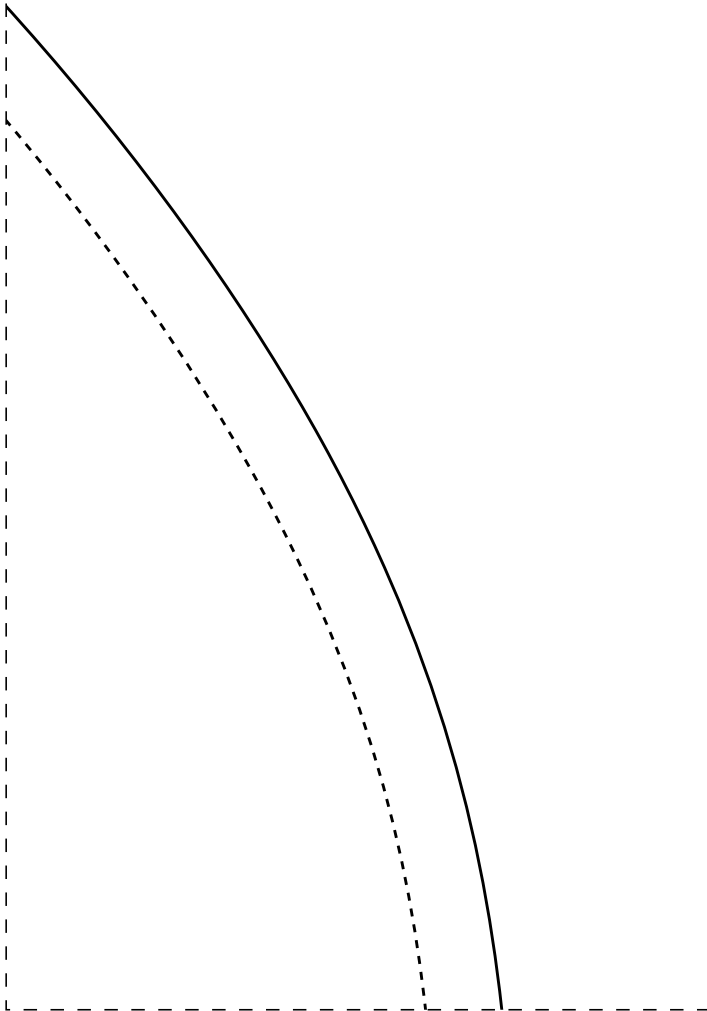
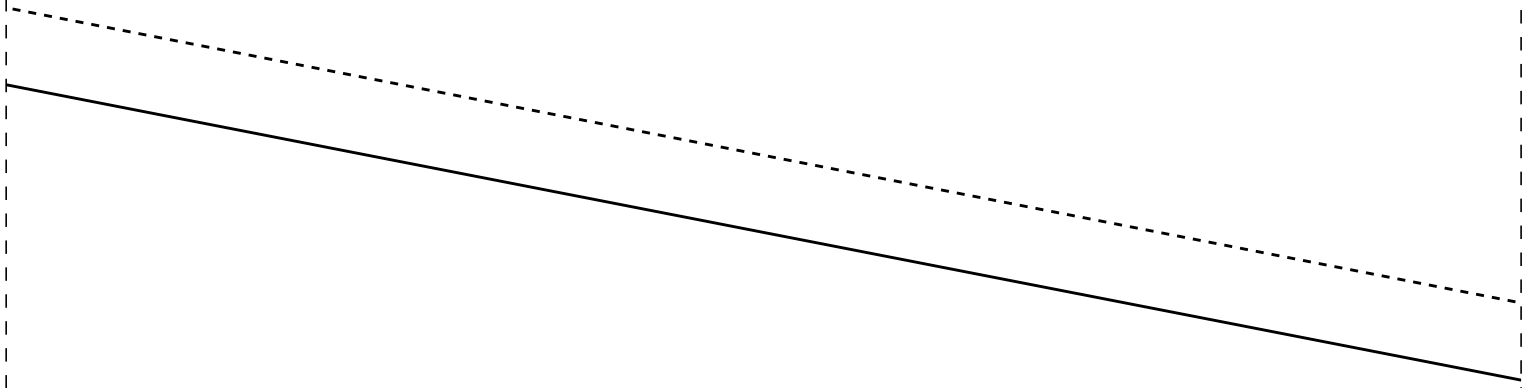

BOLSO 2X-4

IDD33

GABARITO/BS

IDD33

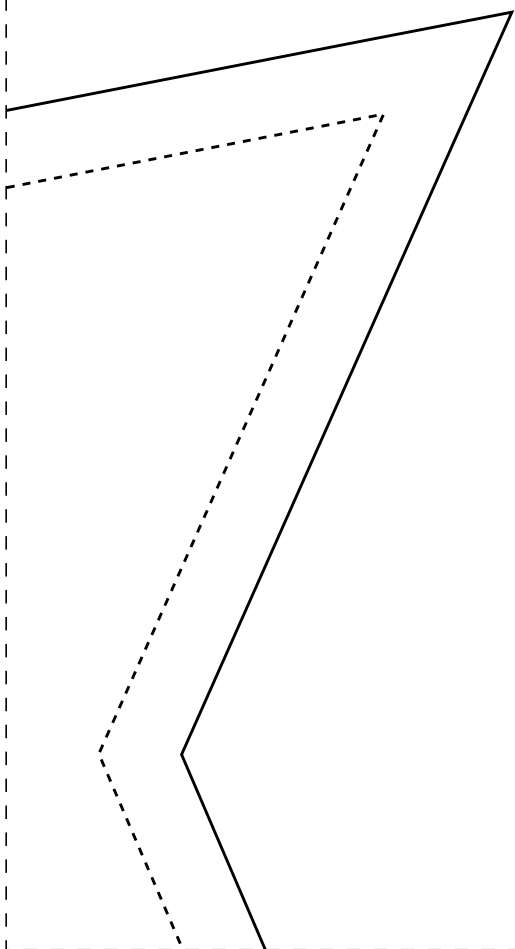

2-13

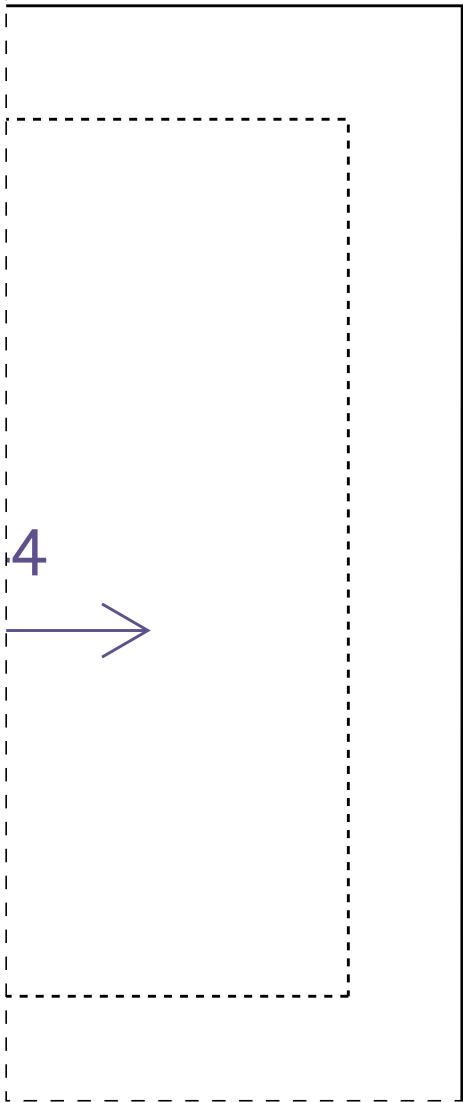
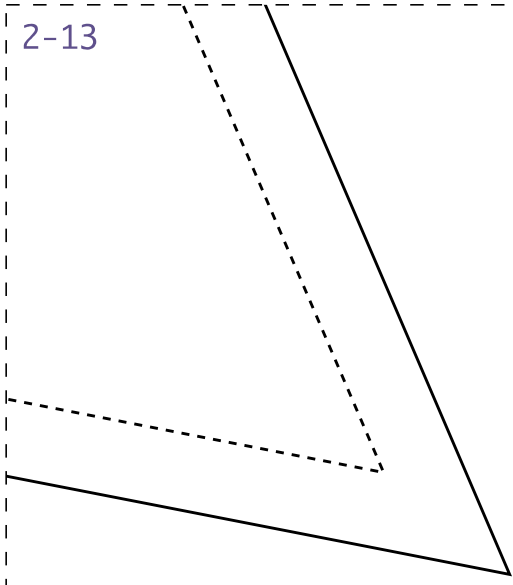

4





-44

