

1-1

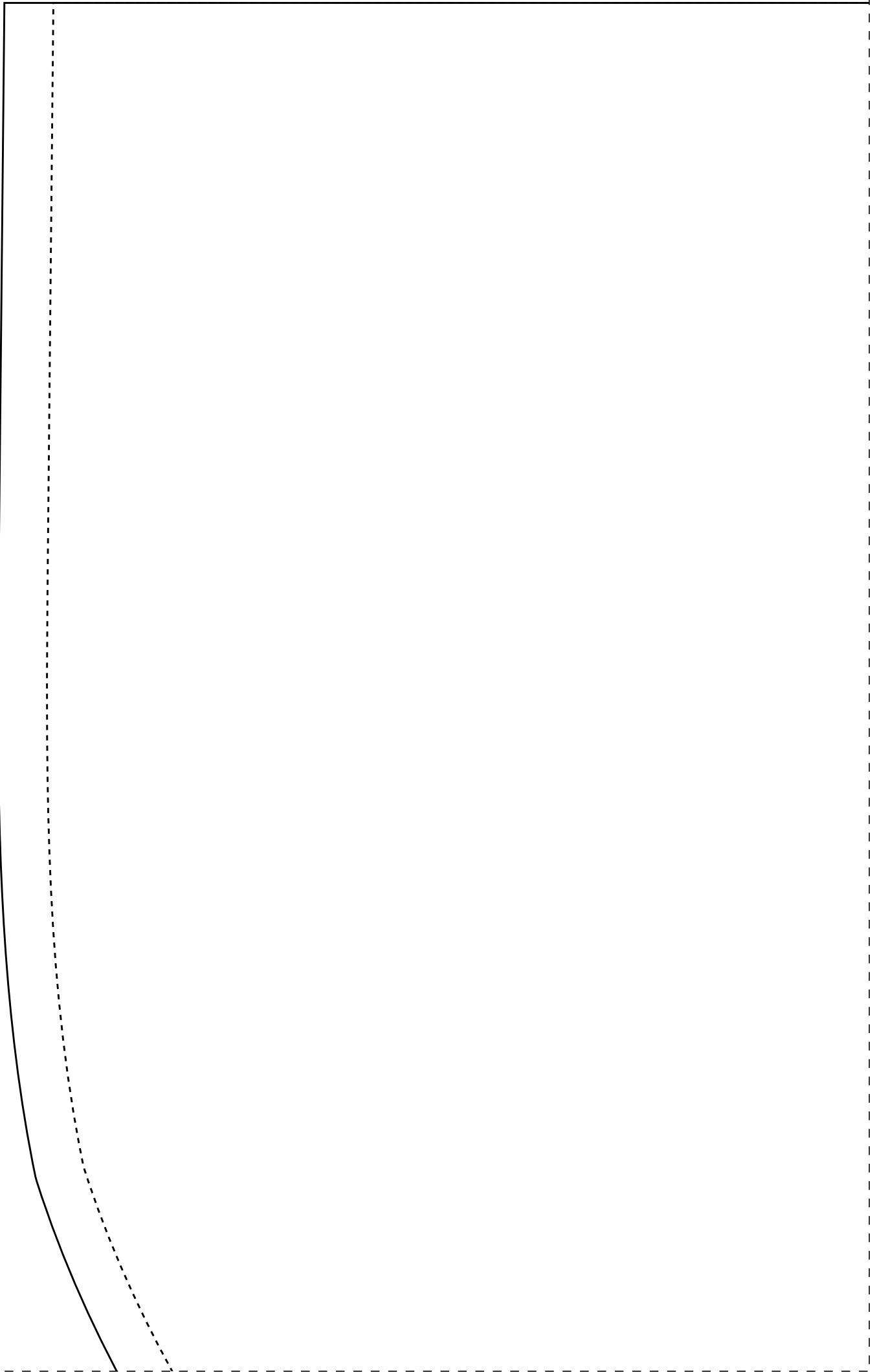

2-1

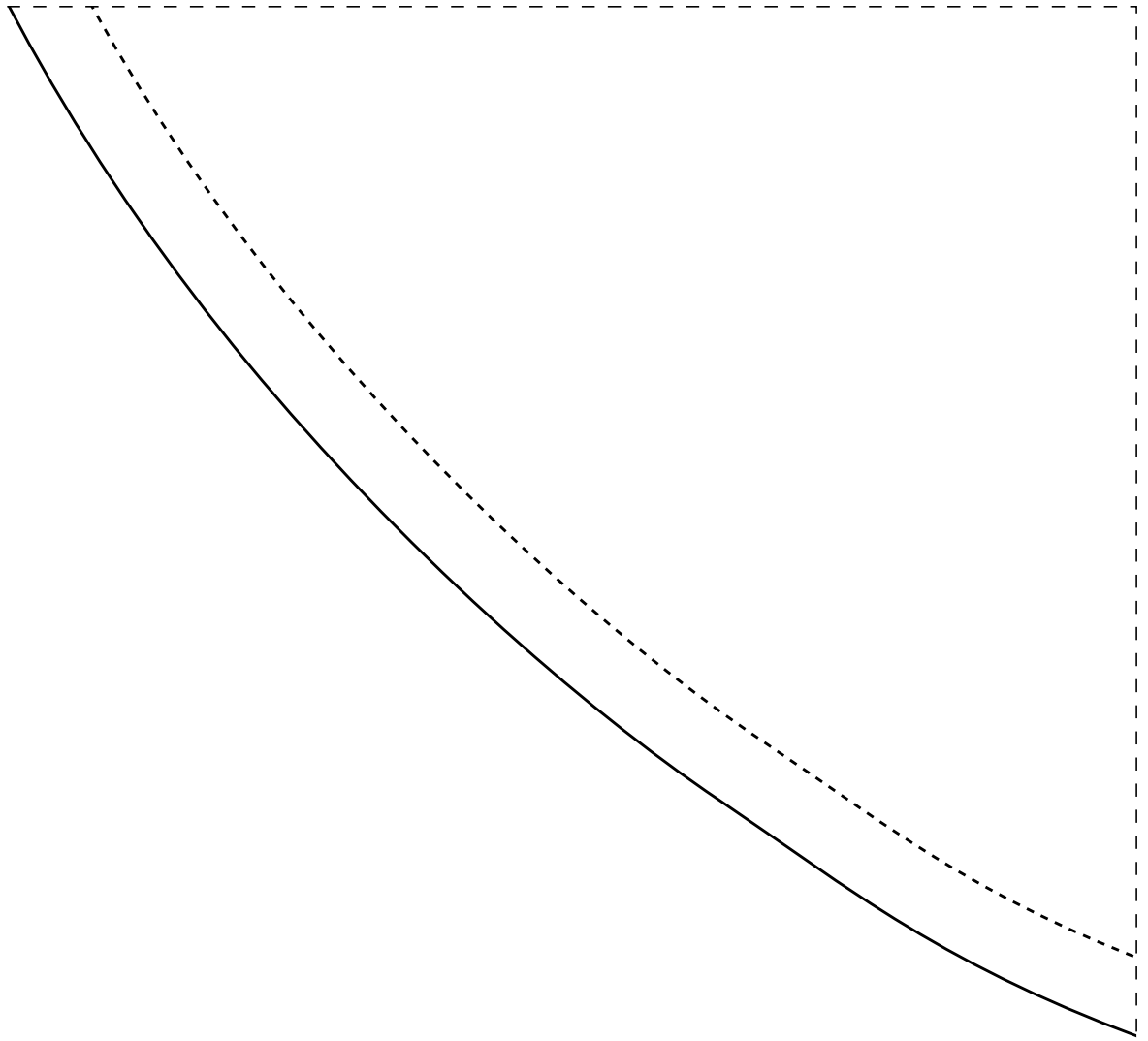

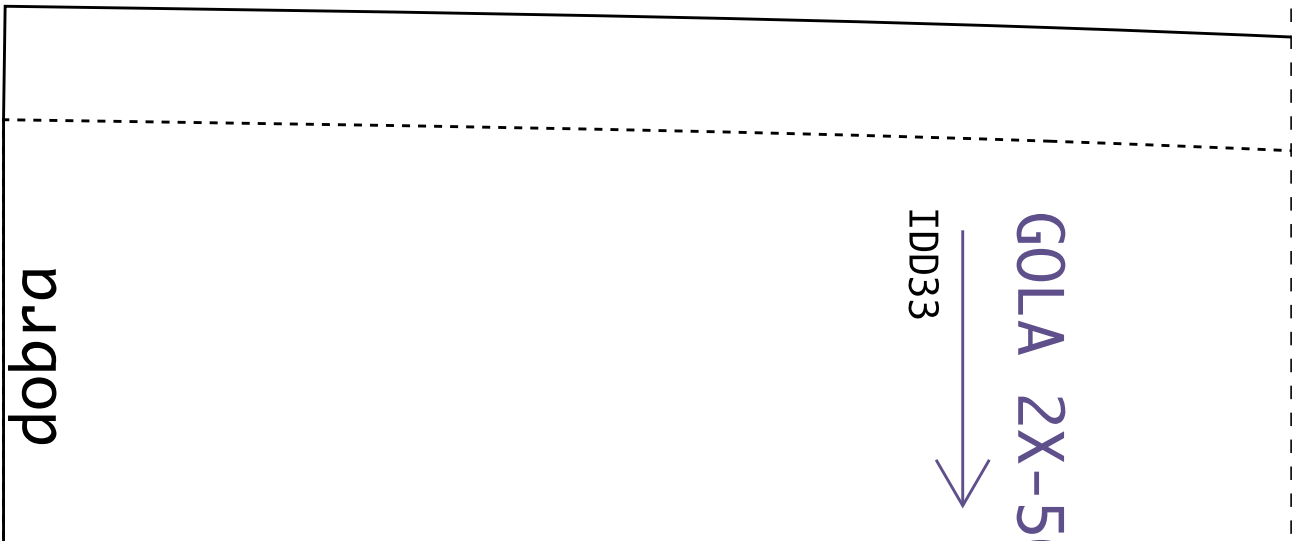
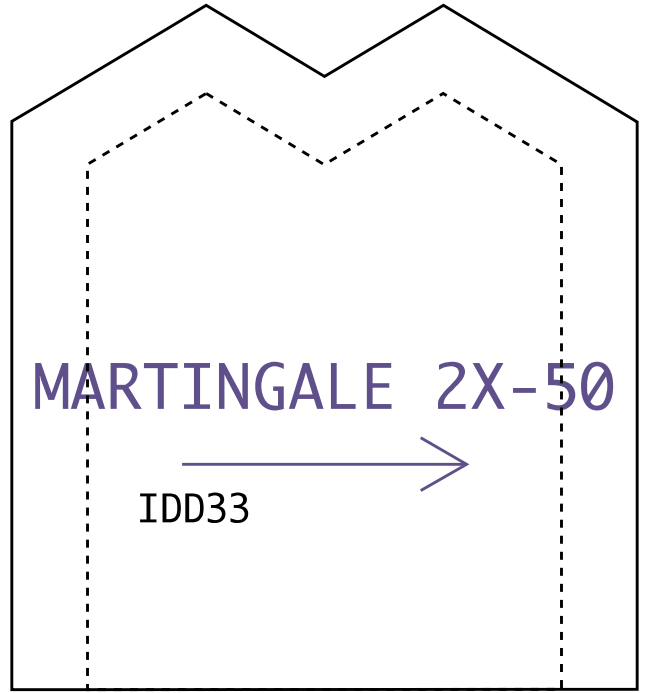

4-1

0

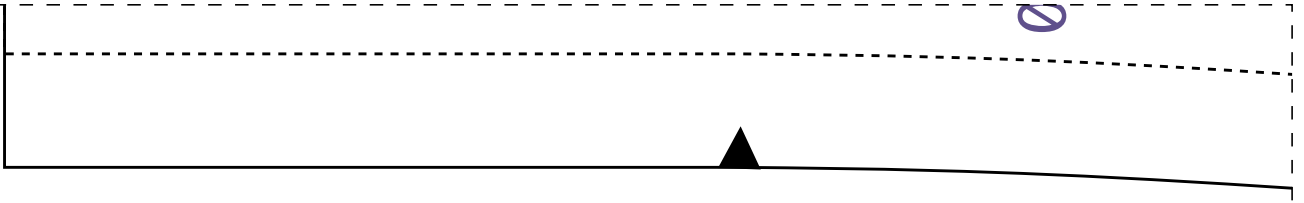



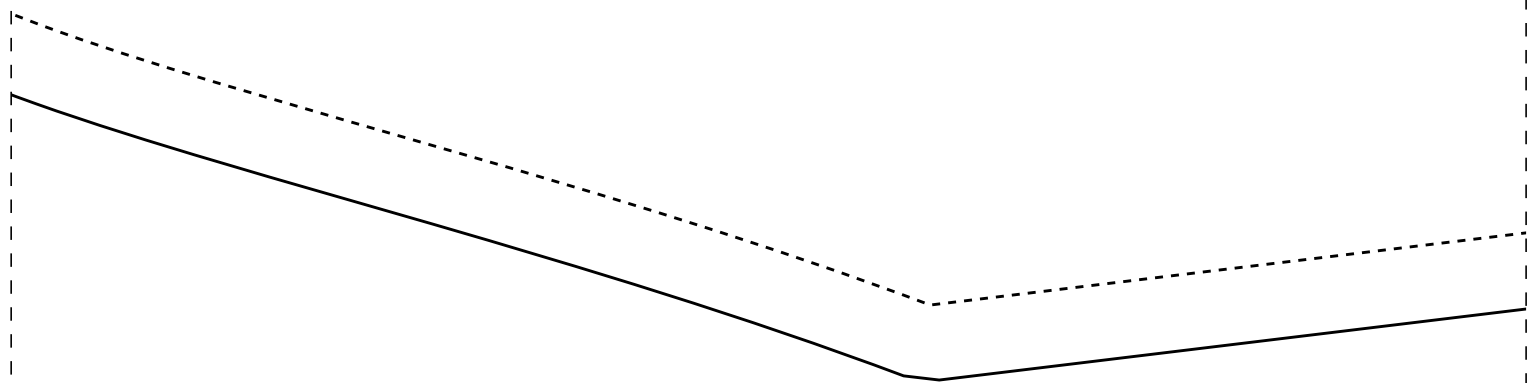

3-2

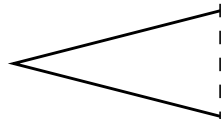
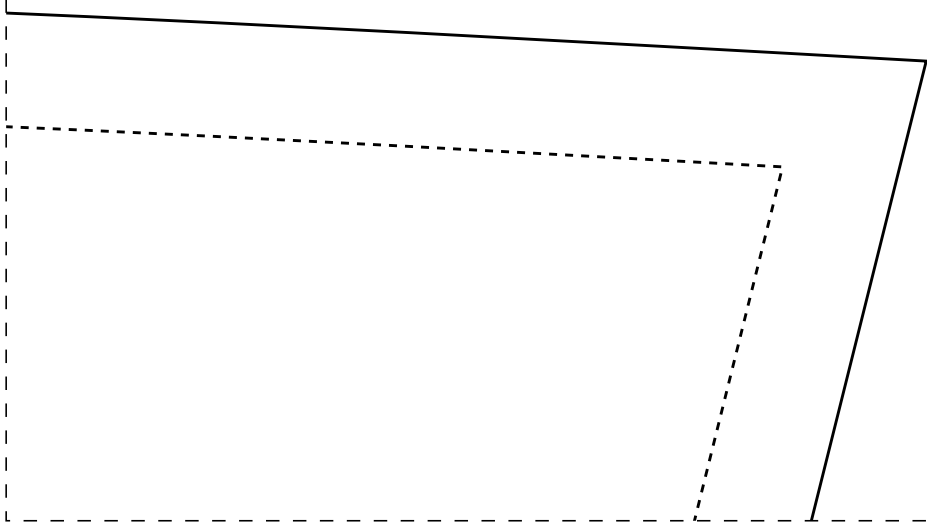

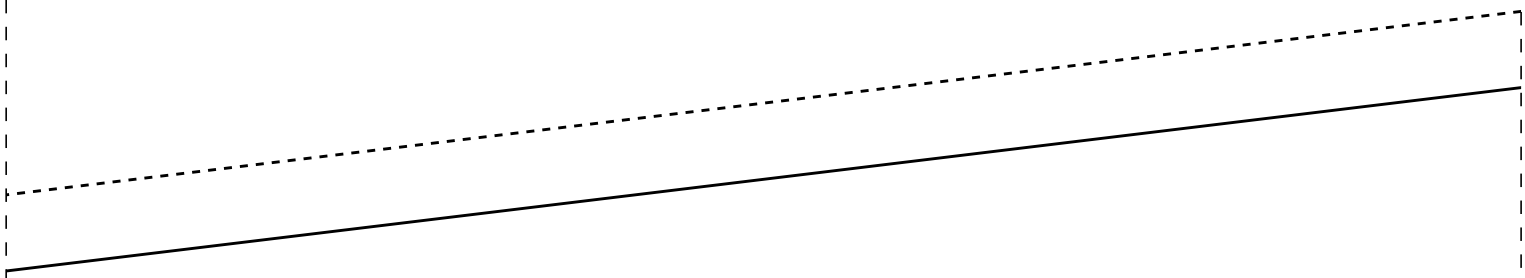

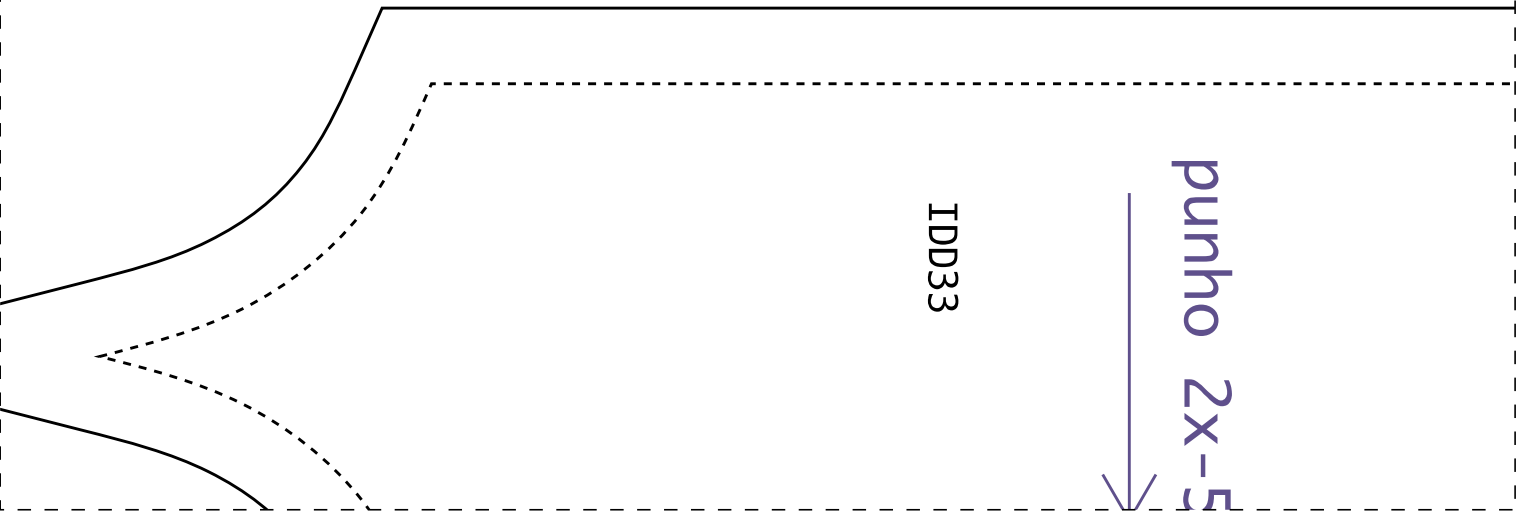
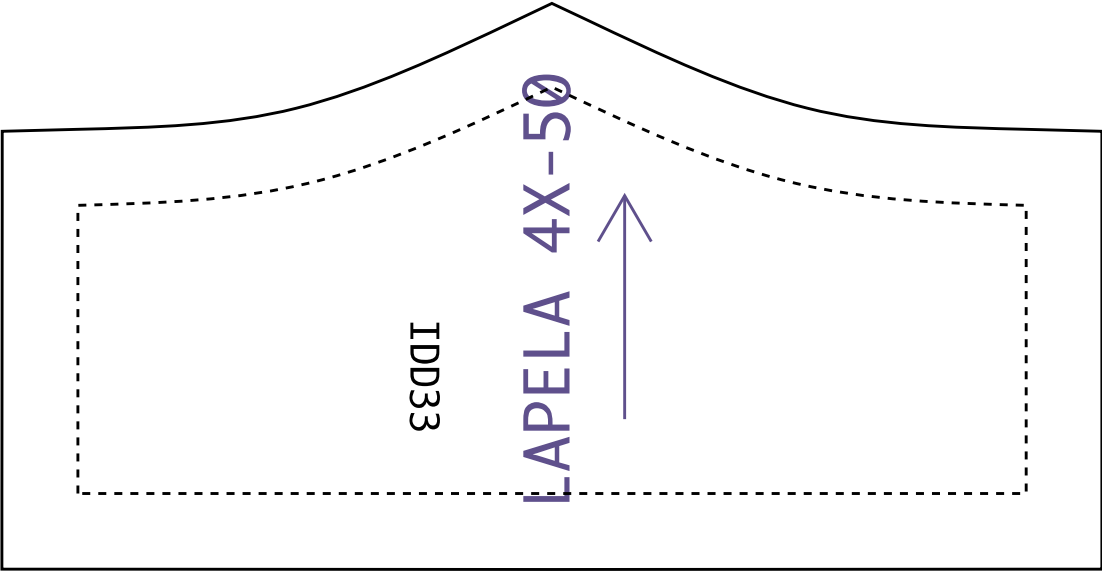

4-3

0

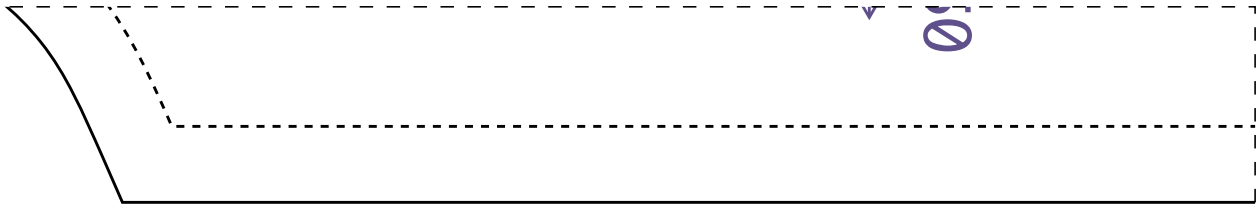

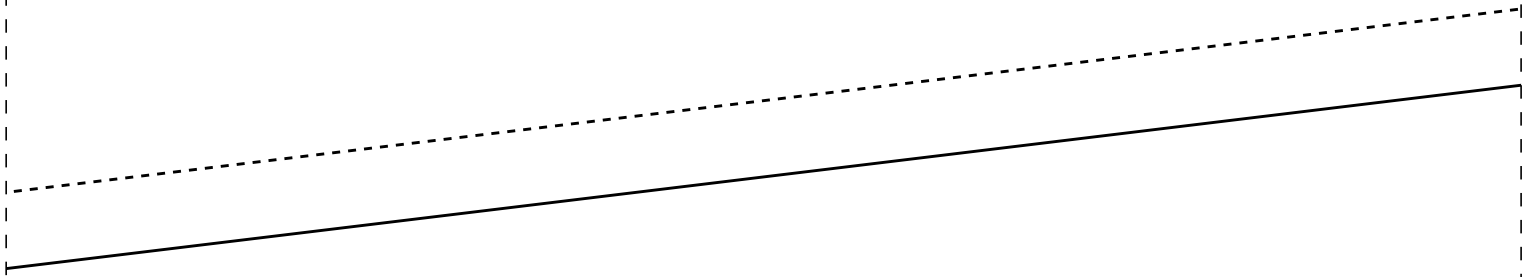

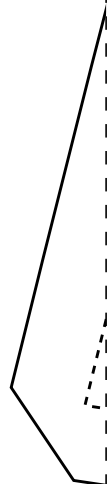

dobra

1-5

dobra

00

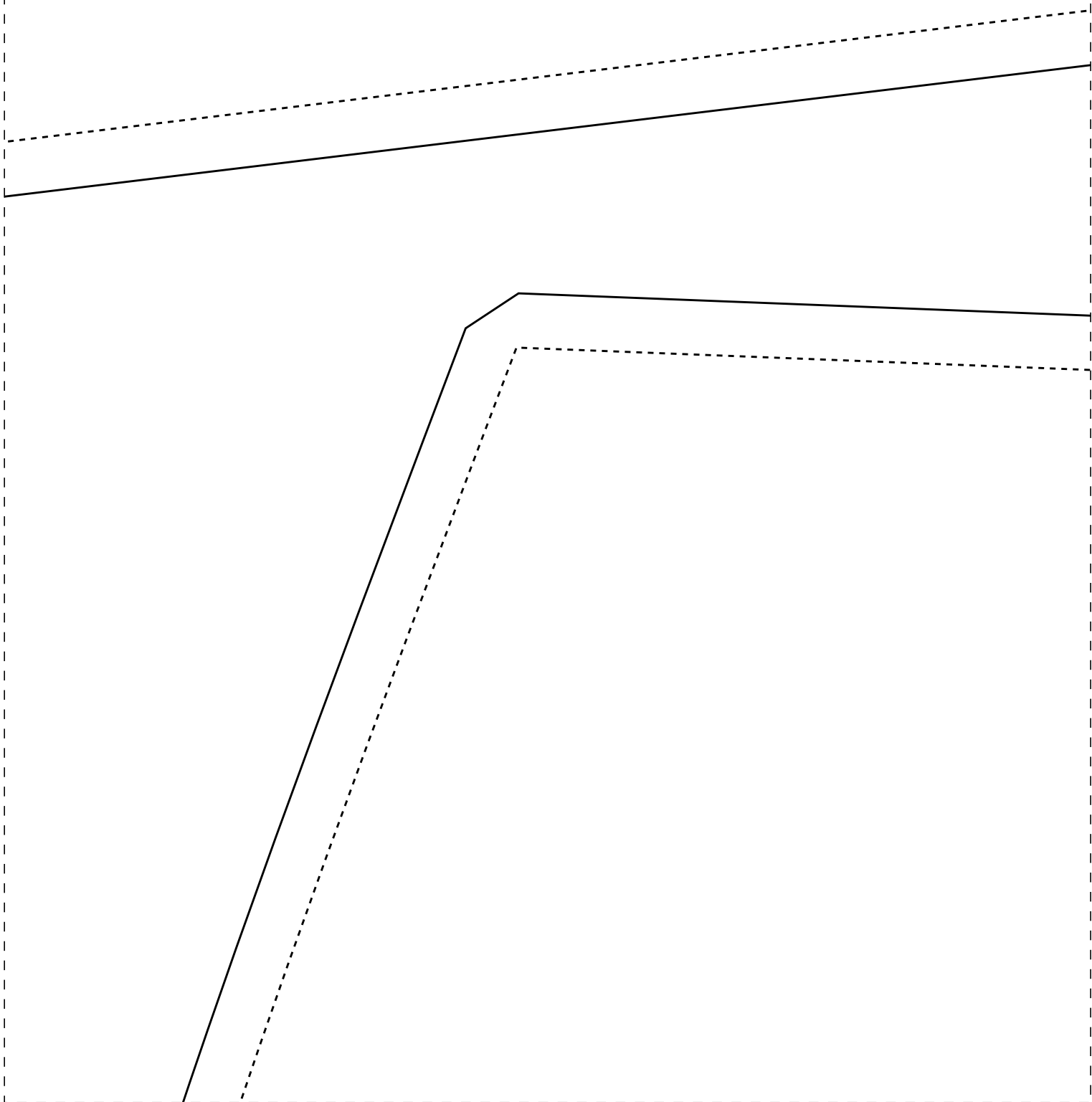

3-5

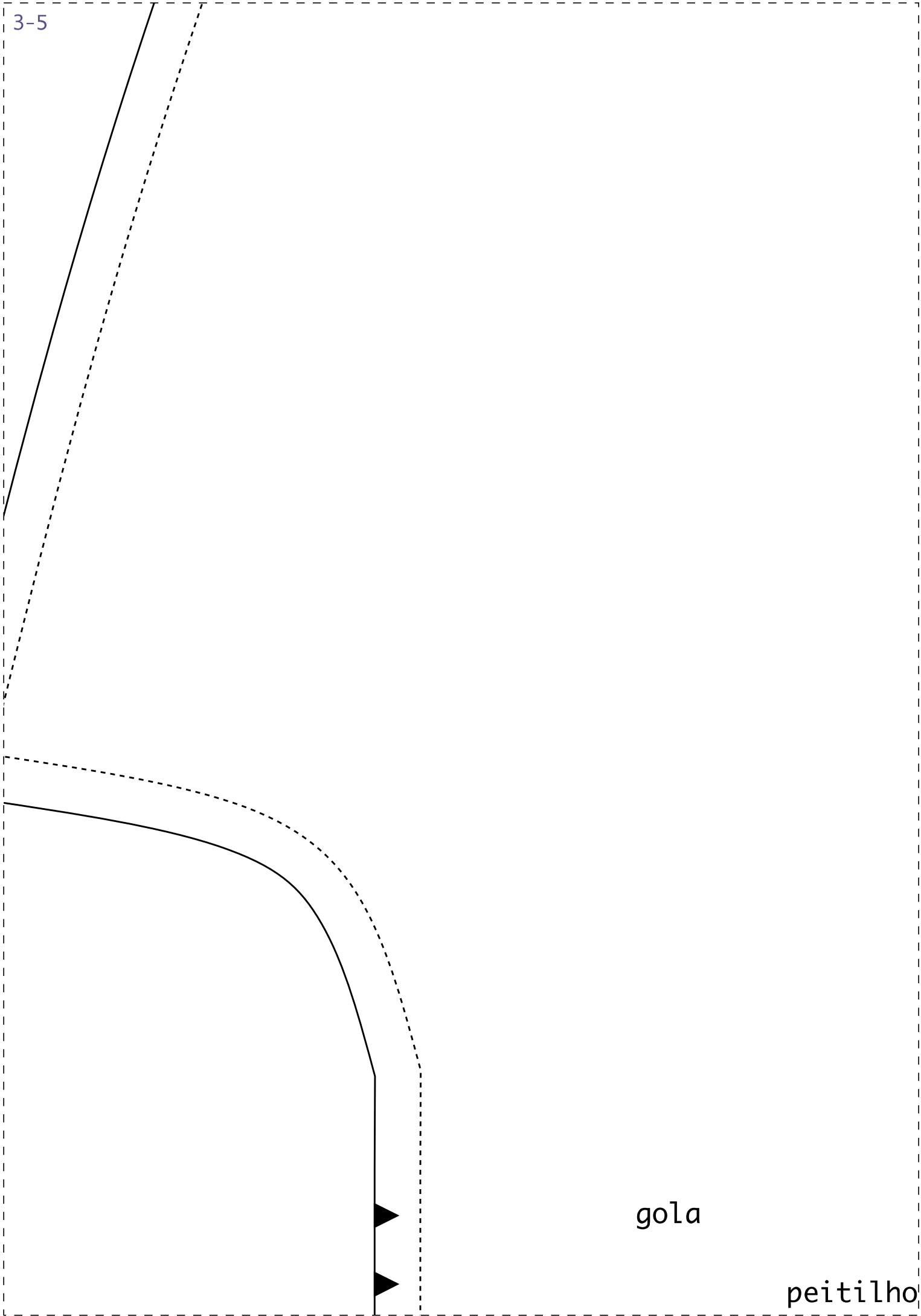

gola

peitilho

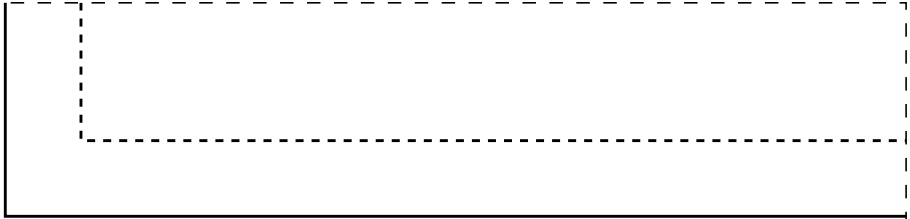

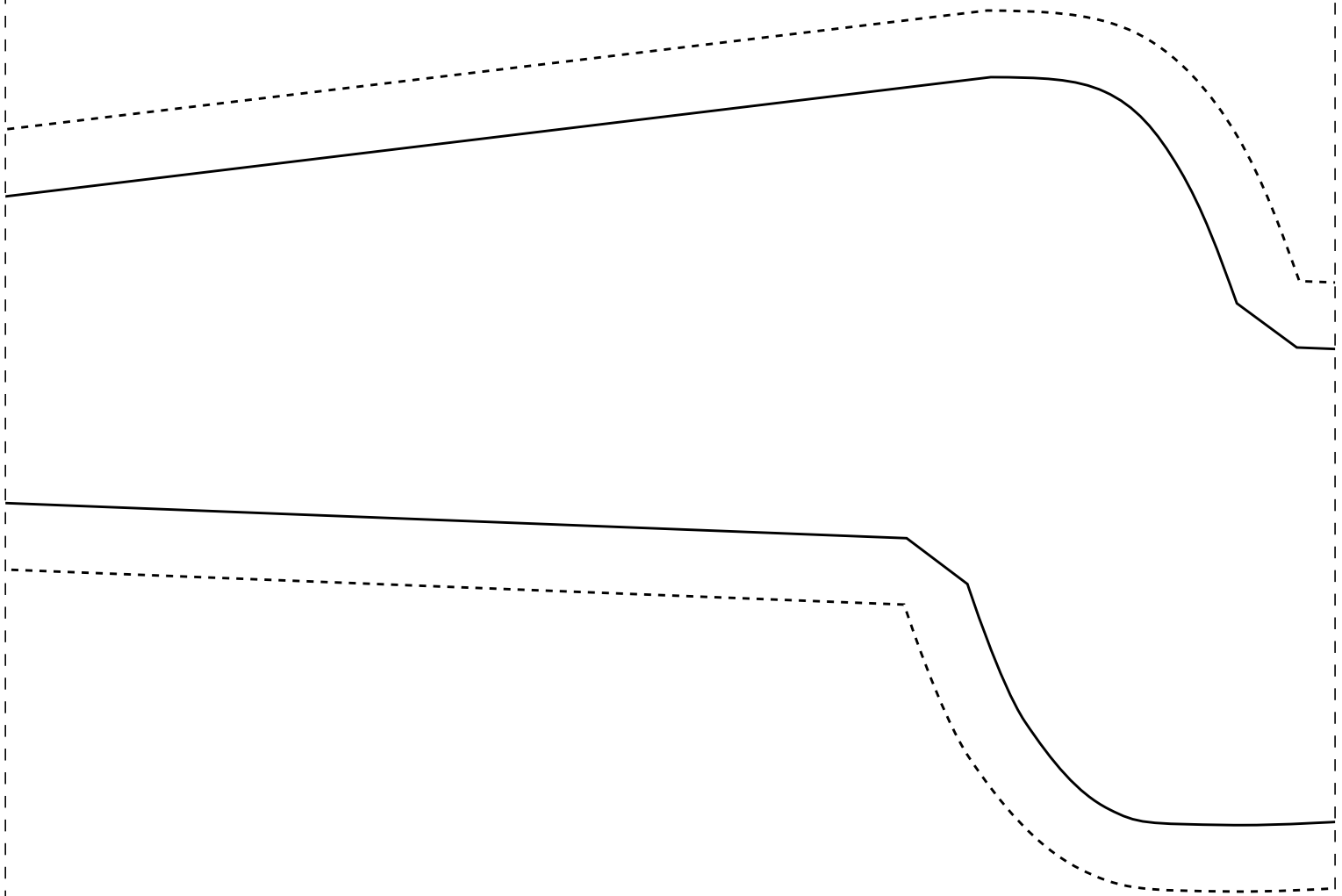

Lapela/bolso

└

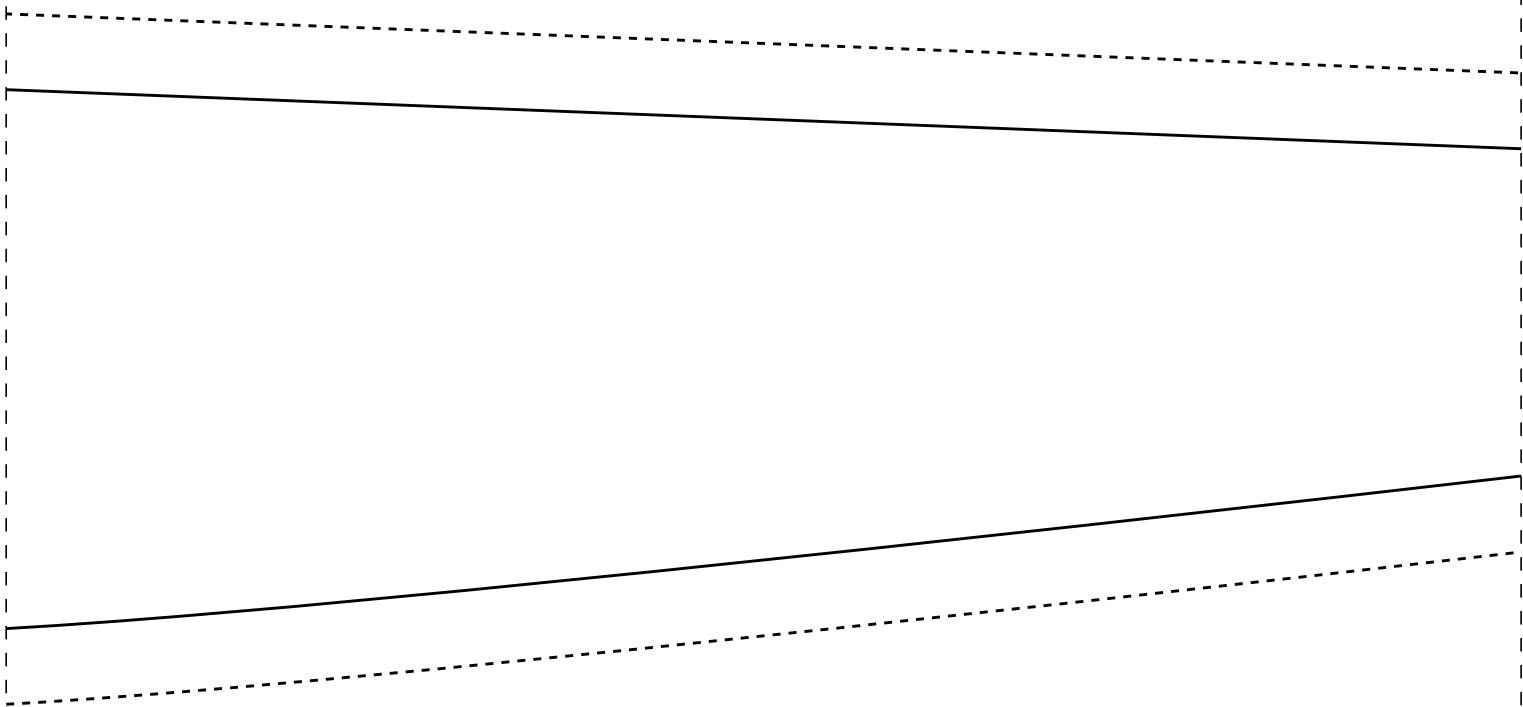

IDD33

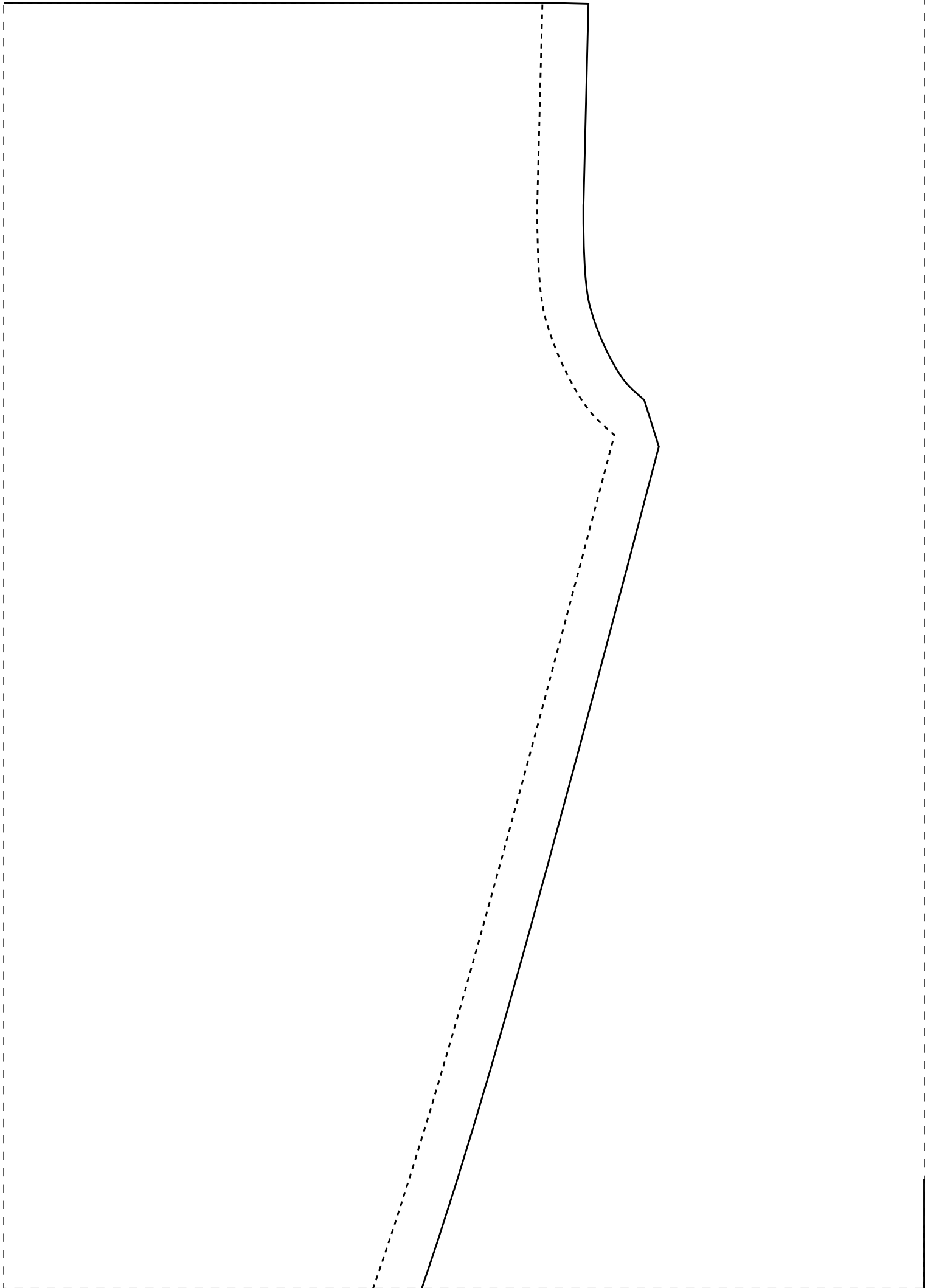

2-8

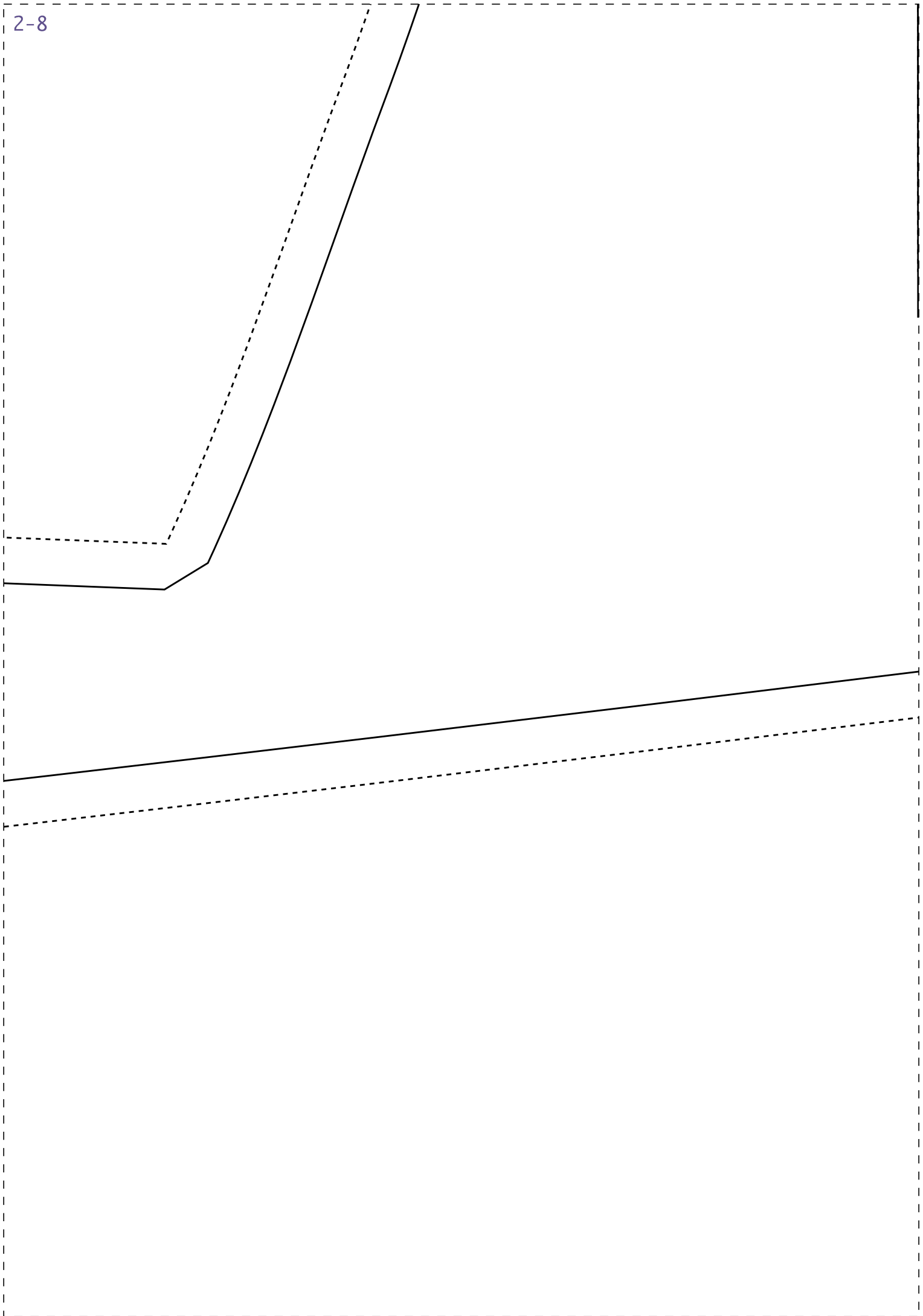

FRENTE 2X-50

FICHA TÉCNICA:

- Tecido plano 1,4m de largura
- Viscolinho, linho, viscose ou similares
- Peça com martingale, bolso e lapela
- Manga com punho
- Peitilho dobrado na peça pronto com 2,5cm
- Fechamento com caseado e botões
- Bainha de lenço ou viés
- 3,3m para todos os tamanhos

dobra

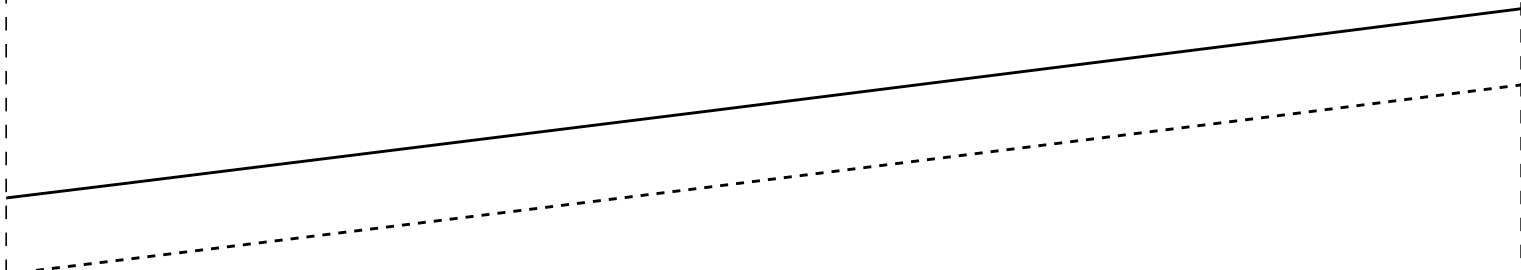





Teste de impressão: ao imprimir seu molde, meça o quadrado que deverá ter a mesma medida informada (4cm), assim você se certificará que ele foi impresso no tamanho correto.

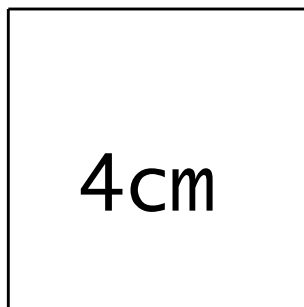

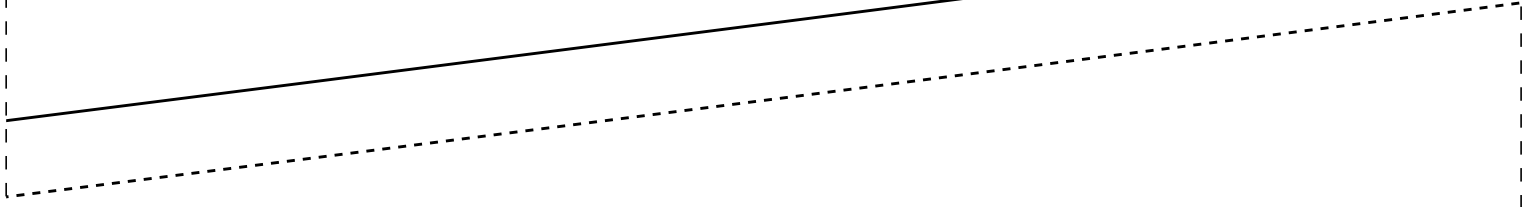
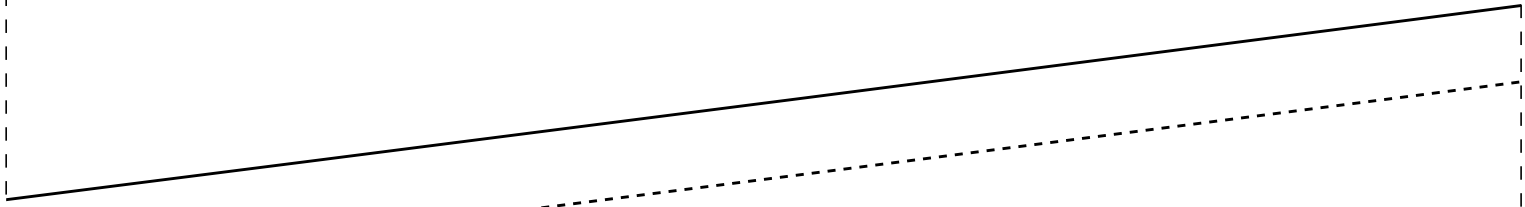

3-10



2-11

IDD33

INTO 1X-50

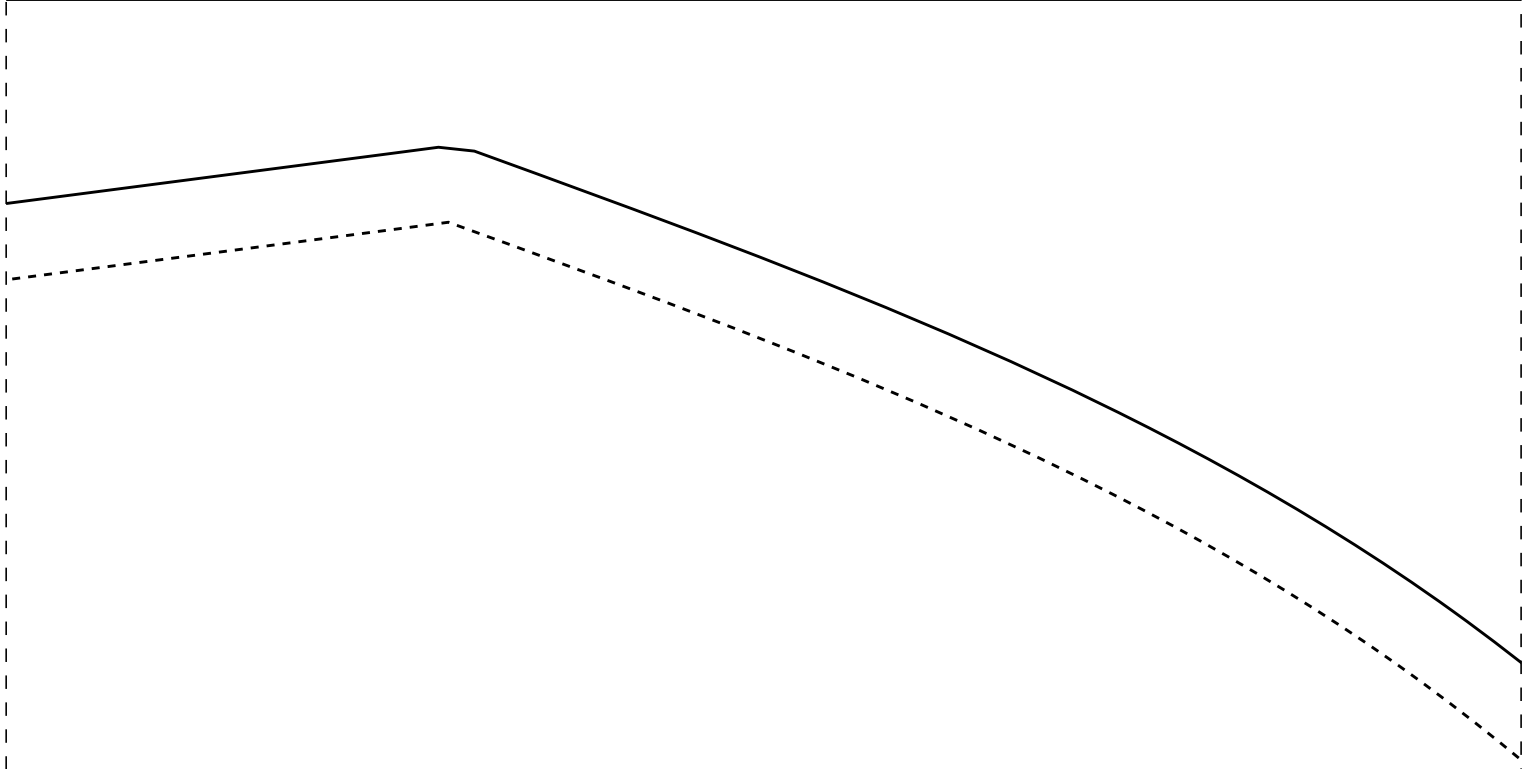



1-12

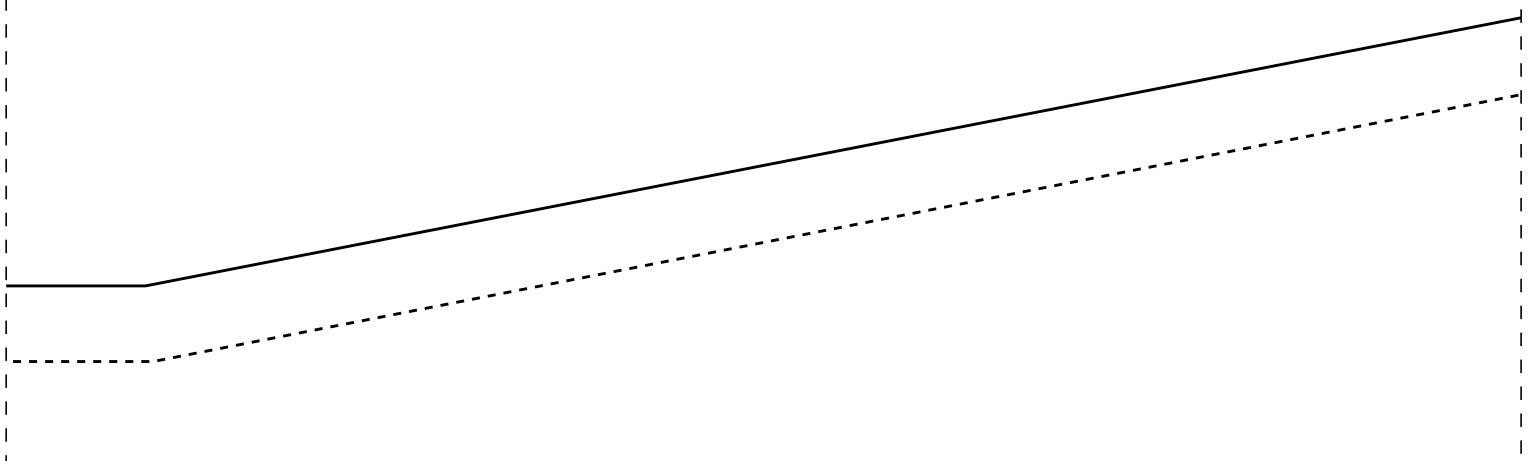

2-12

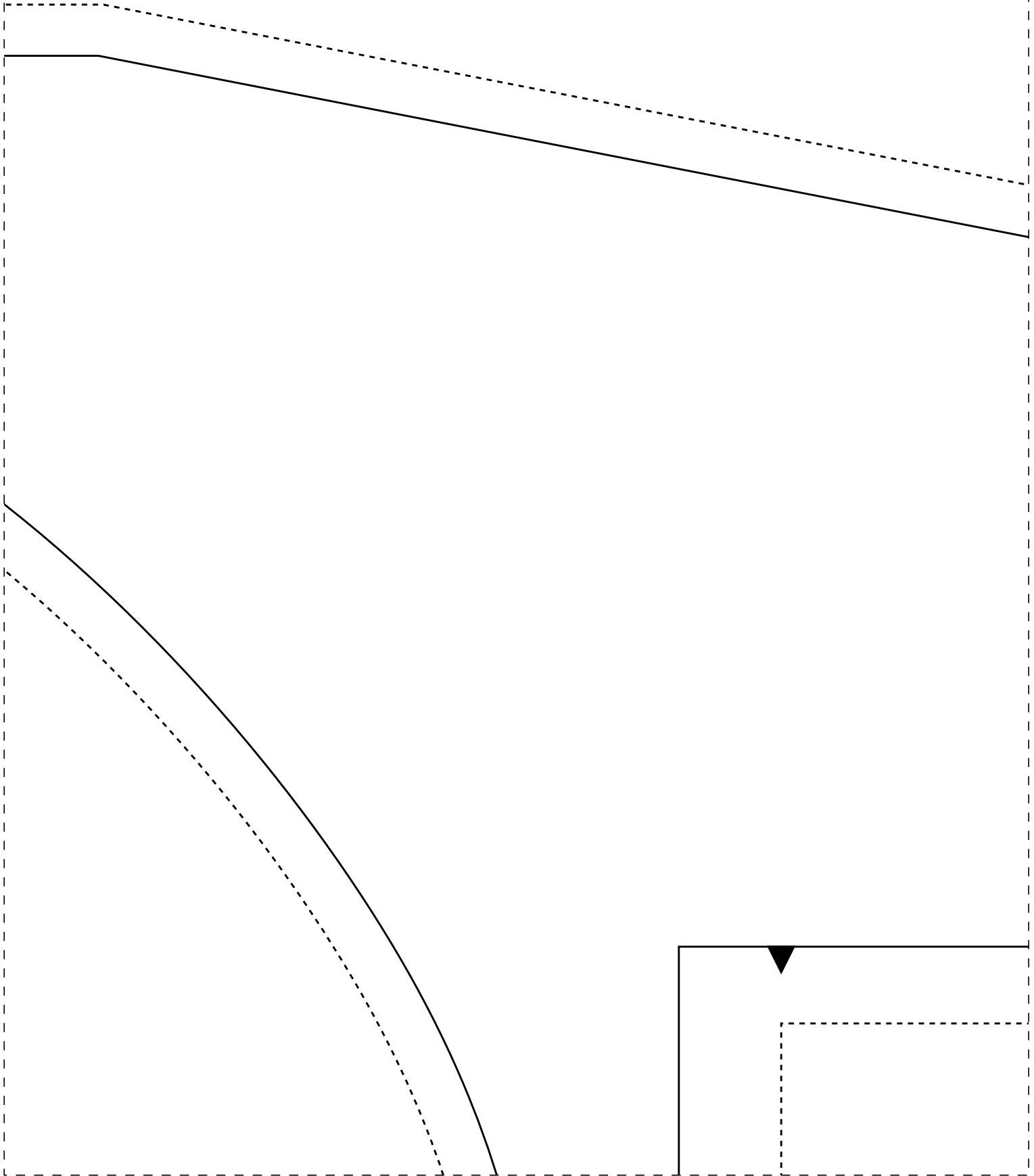

3-12

BC

IDD33

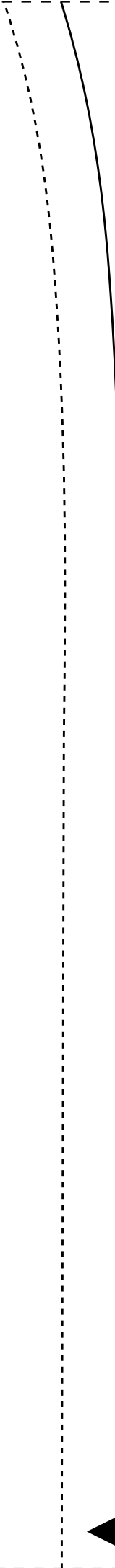
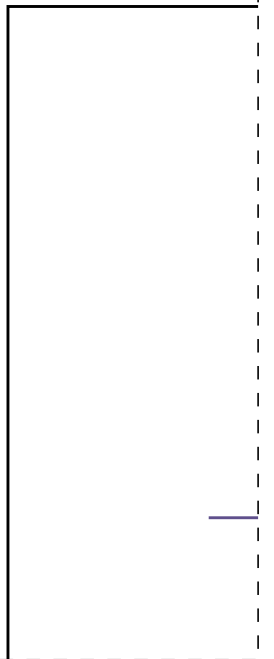
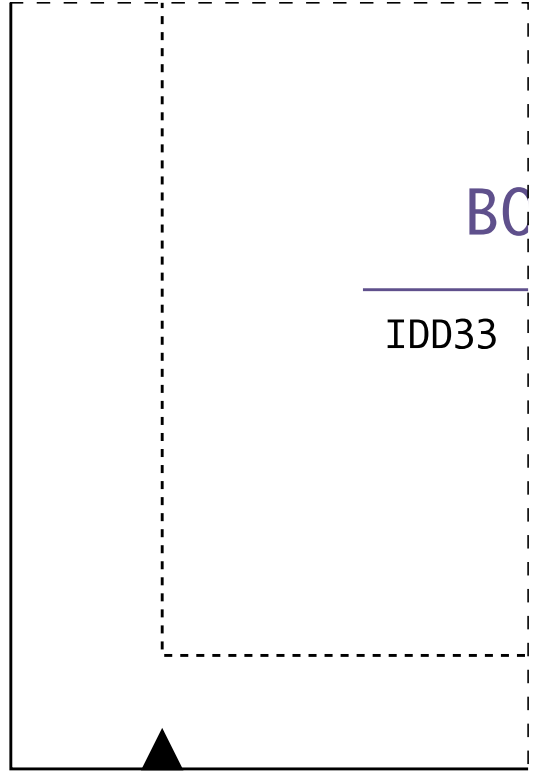

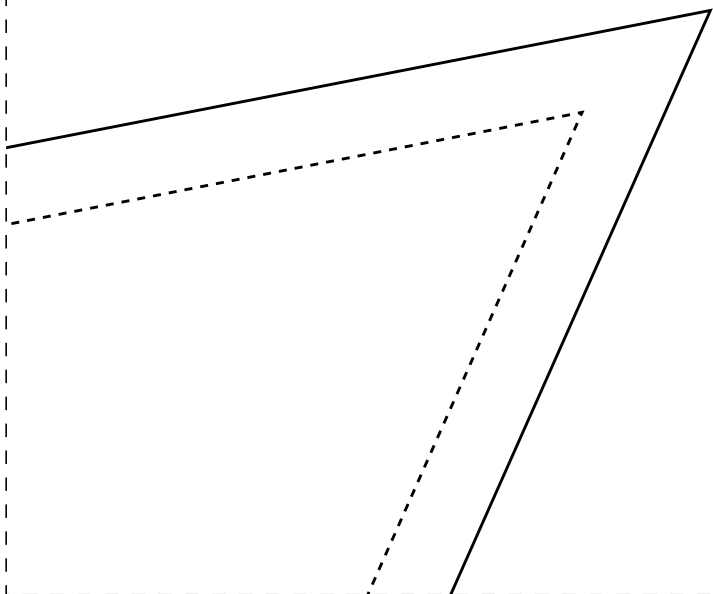

2-13

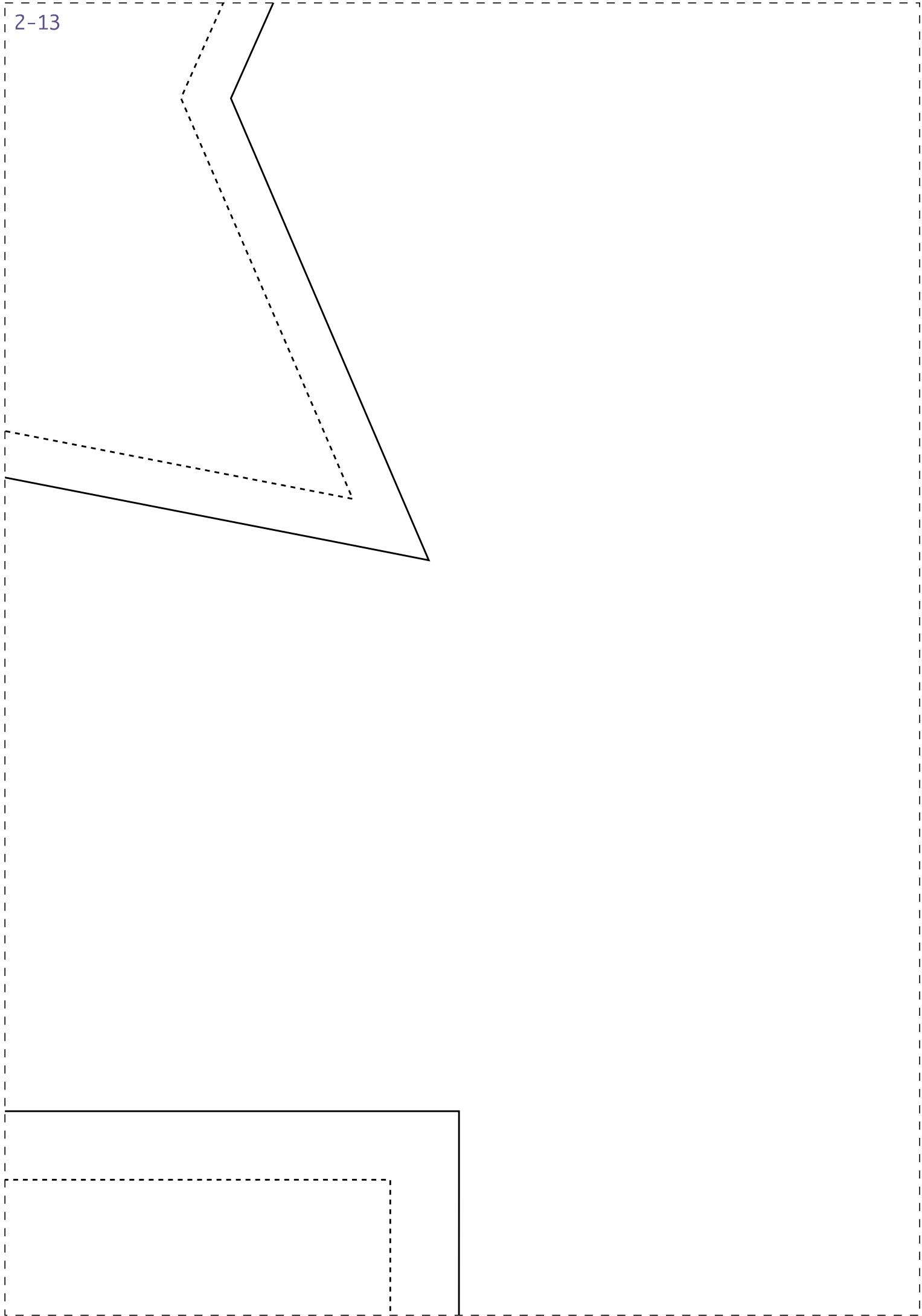

3-13

LSO 2X-50



GABARITO/BS-50



IDD33

